

# **BG8A and BG8B HYDRAULIC WINCH INSTALLATION, MAINTENANCE, AND SERVICE MANUAL**

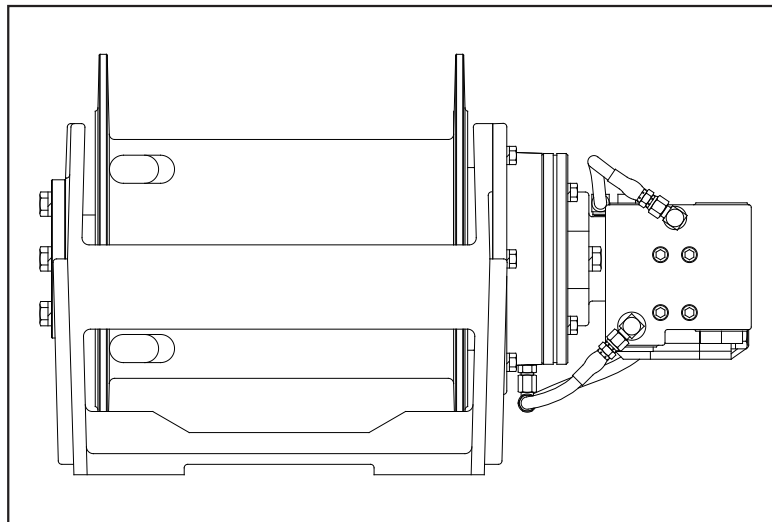

**WRITE HOIST SERIAL NUMBER BELOW**

--	--	--	--	--	--	--	--



**First 2 numbers indicate  
year manufactured**

For serial number location, see page 1

Visit our Web site at [www.paccarwinch.com](http://www.paccarwinch.com) for the most comprehensive collection of winch, hoist, and drive information on the Internet. Most publications and specification sheets are available for downloading.

# FOREWORD

Read and understand this entire publication before operating or servicing your BRADEN/GEARMATIC winch. Retain this manual for future reference. The minimum service intervals specified are for operating hours of the prime mover. This manual contains instructions which provide installation, preventive maintenance, and service information for the Model BG8 series winch. It is suggested that before doing any work on these units, all assembly and disassembly instructions should be read and understood.

Some illustrations in this manual may show details or attachments that are different from your winch. Also, some components have been removed for illustrative purposes.

Continuing product improvement may cause changes in your winch which may not be included in this manual. When a question arises regarding your winch, or this manual, contact your nearest BRADEN/GEARMATIC dealer or the factory Service Department at 1-918-251-8511, Monday - Friday, 8:00 a.m. to 4:30 p.m. CST. Provide the complete winch model and serial number when making inquiries. The model and serial numbers are stamped into the base, to the left of the hydraulic motor.

## PARTS AND SERVICE

BRADEN/GEARMATIC provides parts and service through a network of authorized dealers. Parts and service are not available directly from the factory. For the name of your nearest dealer, consult your local phone directory or call us at the phone number shown above.

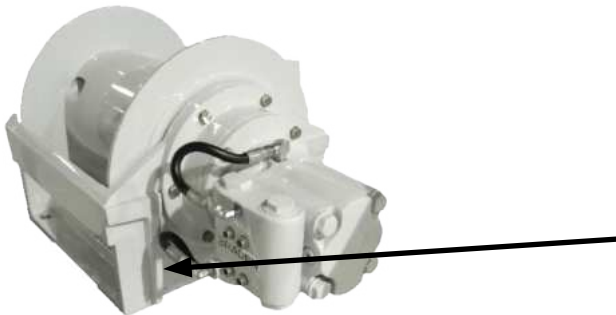

The hoist model number and serial number are stamped onto the data plate of the motor side end plate. Both of these numbers are extremely important in the shipment of the proper replacement parts, and your order should always reference them.

**HOIST SERIAL NUMBER**

**HOIST MODEL NUMBER**

## EXPLANATION OF MODEL NUMBER



BG	8	B	34	039	01	1
BRADEN GEARMATIC	MAX RATING	DESIGN MODEL	GEAR RATIO	MOTOR SIZE	DRUM SIZE	PERSONNEL HANDLING



- BG BRADEN GEARMATIC
- 8 8,000-LB. APPROXIMATE FIRST-LAYER LINE PULL
- B MODEL SERIES RELATING TO DESIGN CHANGES
- 34 TOTAL GEAR REDUCTION  
23 = 23.06:1; 34 = 34.2:1; 59 = 59.06:1; 69/23 (69.19:1 Hoist, 23.06:1 Lower)
- 039 HYDRAULIC MOTOR DISPLACEMENT IN CUBIC INCHES/REV  
(DECIMAL POINT ELIMINATED. EXAMPLE 039 = 3.9 CUBIC INCHES/REV)
- 01 DRUM OPTION
- 1 PERMITS TESTING AND INSPECTION PER API 2C RECOMMENDATIONS

# TABLE OF CONTENTS

Foreword .....	1
Model and Serial Number Explanation.....	1
General Safety Recommendations .....	3
Theory of Operation .....	4
Winch Installation .....	6
Wire Rope Installation .....	8
Preventive Maintenance .....	9
Recommended Oil Change Information.....	10
Troubleshooting.....	11
Winch Disassembly .....	15
Planet Carrier Service .....	17
Motor Support – Brake Cylinder Service.....	19
Brake Clutch Service.....	23
Winch Assembly.....	25
Brake Valve Service.....	27
Reversing Direction of Drum Rotation.....	29
Recommended Fastener Torque .....	30

Safety and informational callouts used in this manual include:

 <b>WARNING</b> 
WARNING – This emblem is used to warn against hazards and unsafe practice which <b>COULD</b> result in severe personal injury or death if proper procedures are not followed.

 <b>CAUTION</b> 
CAUTION – This emblem is used to warn against potential or unsafe practices which <b>COULD</b> result in personal injury and product or property damage if proper procedures are not followed.

 This symbol is used for informational callouts or service tips.
---

# GENERAL SAFETY RECOMMENDATIONS

Safety for operators and ground personnel is of prime concern. Always take the necessary precautions to ensure safety to others as well as yourself. To ensure safety, the prime mover and winch must be operated with care and concern by the operator for the equipment and a thorough knowledge of the machine's performance capabilities. The following recommendations are offered as a general safety guide. Local rules and regulations will also apply.

1. Read all warning and caution tag information and become familiar with all controls before operating winch.
2. Never attempt to clean, oil or perform any maintenance on a machine with the engine running, unless instructed to do so in this manual.
3. Never operate winch controls unless you are properly positioned at the operators station and you are sure personnel are clear of the work area.
4. Assure that personnel who are responsible for hand signals are clearly visible and that the signals to be used are thoroughly understood by everyone.
5. Ground personnel should stay in view of the operator and clear of winch drum. Do not allow ground personnel near winch line under tension. A safe distance of at least 1-1/2 times the length of the cable should be maintained. Never allow anyone to stand under a suspended load.
6. On machines having hydraulically, mechanically and/or cable controlled equipment, be certain the equipment is either lowered to the ground or blocked securely before servicing, adjusting and/or repairing the winch. Always apply the prime mover parking brakes and lower equipment before dismounting the prime mover.
7. Inspect rigging, winch and hydraulic hoses at the beginning of each work shift. Defects should be corrected immediately.
8. Keep equipment in good operating condition. Perform scheduled servicing and adjustments listed in the "Preventive Maintenance" section of this manual.
9. An equipment warm-up procedure is recommended for all start-ups and is essential at ambient temperatures below +40°F (4°C). Refer to "Warm-up Procedure" listed in the "Preventive Maintenance" section of this manual.
10. Be sure of equipment stability before operating winch.
11. The winches described herein are neither designed nor intended for use or application to equipment used in the lifting or moving of persons.
12. Do not exceed the maximum pressure or flow stated in the winch specifications.
13. Operate winch line speeds to match job conditions. Avoid sudden "shock" loads or attempting to "jerk" load free. This type of operation may cause heavy loads in excess of rated capacity, which may result in failure of cable and winch.
14. Leather gloves should be used when handling winch cable.
15. Never attempt to handle winch cable when the hook end is not free. Keep all parts of body and clothing clear of cable rollers, cable entry area of fairleads and winch drum.
16. When winding winch cable on the winch drum, never attempt to maintain tension by allowing winch cable to slip through hands. Always use "Hand-Over-Hand" technique.
17. Install guarding to prevent personnel from getting any part of body or clothing caught at a point where the cable is wrapped onto the drum or drawn through fairlead guide rollers.
18. Do not weld on any part of the winch.
19. Do not use knots to secure or attach winch cable. Use correct size cable anchor for cable and pocket in winch drum.
20. Use recommended hydraulic oil and gear lubricant.
21. Keep hydraulic system clean and free from contamination at all times.
22. The BRADEN/GEARMATIC wire rope anchors are capable of supporting the rated load when installed properly. For additional safety, ALWAYS maintain a minimum of five (5) wraps of wire rope on the drum.

# THEORY OF OPERATION

## DESCRIPTION OF WINCH

The winch has three basic assemblies:

1. Hydraulic motor assembly and brake valve
2. Cable drum assembly
3. Brake cylinder and motor adapter

The hydraulic motor is bolted to the motor adapter which in turn is bolted to the brake cylinder and the winch base. The cable drum assembly is supported by antifriction bearings which are located by the brake housing at one end and the bearing support at the other end. The ring gear for both planetary sets is machined on the inside surface of the cable drum.

## PLANETARY GEAR TRAIN

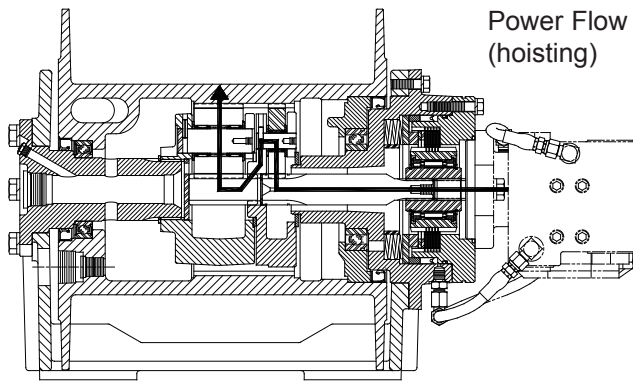

The hydraulic motor shaft is directly coupled to the inner brake hub which is connected to the input shaft which acts as the sun gear for the primary planetary set. When driven by the input shaft, the primary planet gears walk around the ring gear machined in the cable drum and drive the primary planet carrier.

The primary planet carrier drives the output sun gear which drives the output planet gears. The output planet carrier is splined to the bearing support and cannot rotate. As the output planet gears are driven by the output sun gear, they drive the ring gear/cable drum.

## DUAL BRAKE SYSTEM

The dual brake system consists of a dynamic brake system and a static brake system.

The dynamic brake system has two operating components:

1. Brake valve assembly
2. Hydraulic motor

The brake valve is basically a counterbalance valve. The counterbalance valve is mounted to the hoist port of the motor on units with 020, 029 and 039 motors. Units with the 071 motor use a counterbalance valve cartridge in the brake valve block which is bolted to the motor. The operational theory of both systems is the same. A check valve allows free flow of oil to the motor in the haul-in direction and a pilot operated, spring-loaded spool valve blocks the flow of oil out of the motor when the control valve is placed in neutral. When the control valve is placed in the pay-out position, the spool valve remains closed until sufficient pilot pressure is applied to the end of the spool to shift it against spring pressure and open a passage. After the spool valve cracks open, the pilot pressure becomes flow-dependent and modulates the spool valve opening which controls the pay-out speed. .

The static brake system has three operating components:

1. Spring-applied, multiple friction-disc brake pack
2. Overrunning brake clutch assembly
3. Hydraulic brake cylinder and spring plate

The static brake consists of alternately stacked friction and steel brake discs. The steel brake discs are externally splined to the motor adapter and cannot rotate. The friction discs are internally splined to the outer brake hub of the overrunning brake clutch. When compressed by spring force, the brake pack locks the overrunning brake clutch outer brake hub to the motor adapter.

The static brake is released by the pilot pressure at a pressure lower than that required to open the pilot operated brake valve. This sequence assures that dynamic braking takes place in the brake valve and that little, if any, heat is absorbed by the friction brake.

The friction brake is primarily a load holding brake and will provide dynamic braking only during extremely slow operation when there is insufficient flow to open the brake valve.

The sprag type overrunning brake clutch is installed between the inner brake race and the outer brake hub. The overrunning brake clutch, allows the inner brake race and input shaft to turn freely in the direction to haul in cable and locks up to force the friction brake discs to turn with the inner brake race and input shaft to pay out cable. The brake pack remains fully applied when hauling in cable and must be released by pilot pressure to allow the brake discs to turn freely and pay-out cable.

## DUAL BRAKE SYSTEM – OPERATION

When hoisting or pulling a load, the brake clutch allows free rotation of the inner brake race and input shaft. The sprag cams lay over and permit the inner race to turn free of the outer brake hub (Figure 1). The friction brake remains fully engaged. The winch, in raising a load, is not affected by any braking action during haul-in.

**Figure 1**

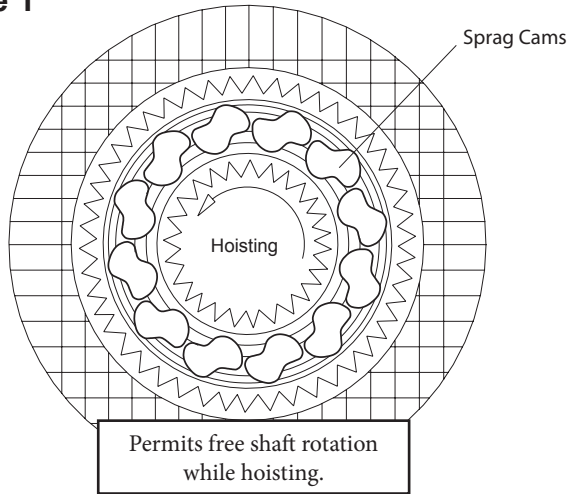

When the haul-in operation is stopped, the load attempts to turn the input shaft in the opposite direction. This reversed input causes the sprag cams to instantly engage and firmly lock the inner brake race to the outer brake hub (Figure 2).

**Figure 2**

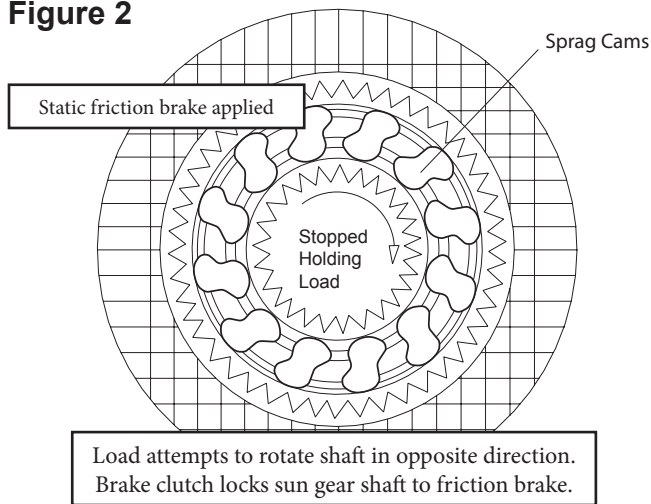

When the winch is powered in reverse, to pay-out cable, the motor and gear train will not rotate until sufficient pilot pressure is supplied to open the brake valve. The friction brake within the winch will completely release at a pressure lower than that required to open the brake valve. The extent to which the brake valve opens will determine the amount of oil that can flow through it and the speed at which the load will be lowered. Increasing the flow of oil to the winch motor will cause the pressure to rise and the opening in the brake valve to enlarge, speeding up the descent of the load. Decreasing this flow causes the pressure to lower and the opening in the brake valve to decrease thus slowing the descent of the load.

When the control valve is returned to neutral or "hold," the pilot pressure will drop and the brake valve will close, stopping the load. The friction brake will engage and hold the load after the brake valve has closed.

When lowering a load very slowly for precise positioning, no oil flow actually occurs through the winch motor. The pressure will build up to a point where the friction brake will release sufficiently to allow the load to rotate the motor through its own internal leakage. This feature results in a very slow speed and extremely accurate positioning.

The friction brake receives very little wear in the lowering operation. All of the heat generated by the lowering and stopping of a load is absorbed by the hydraulic oil where it can be readily dissipated.

# WINCH INSTALLATION

1. The winch should be mounted with the centerline of the drum in a horizontal position. The mounting plane of the base may be rotated in any position around this centerline.

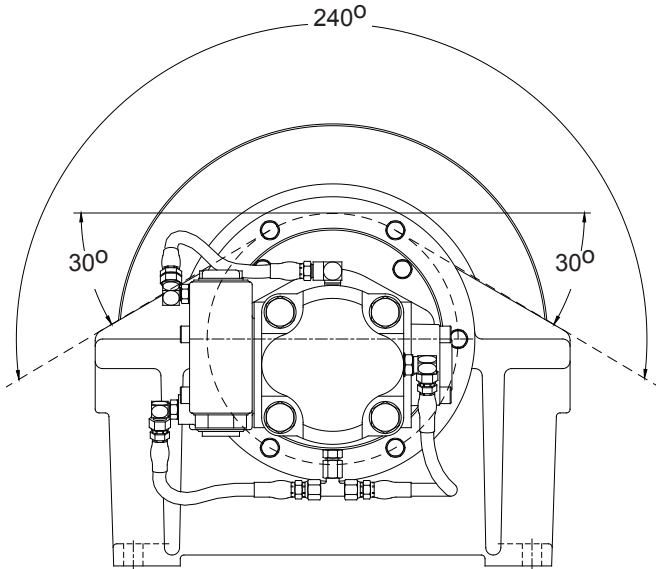

It is important that the winch is mounted on a surface that will not flex when the winch is in use, and cause binding of the gear train. Binding in the gear train will result in accelerated wear and heat. Also, be sure the winch is mounted on a flat surface. If necessary, use shim stock to insure the mounting surface is flat within 0.020 inch (0.5 mm).

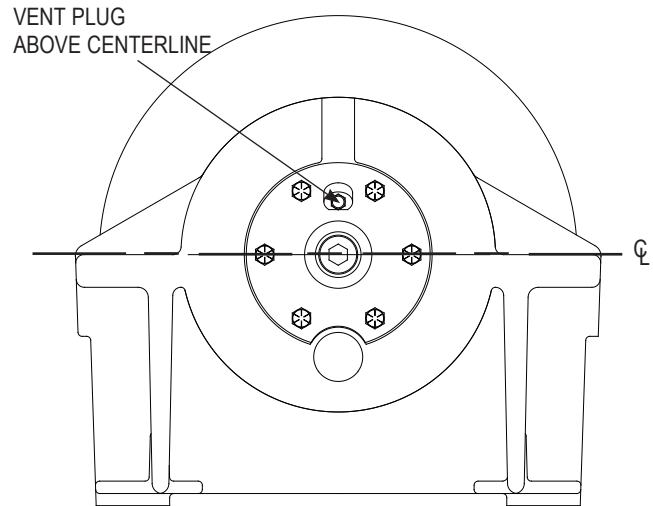

2. Because of the design of the mounting base, the direction of line pull should only be as shown in the above illustration. Line pulls in any other direction must be approved by BRADEN Engineering.

4. The vent plug must always be located above the horizontal centerline. If the winch is mounted on a pivoting surface, be sure vent plug remains above the centerline in all positions. If necessary, reposition bearing support and vent plug as follows:

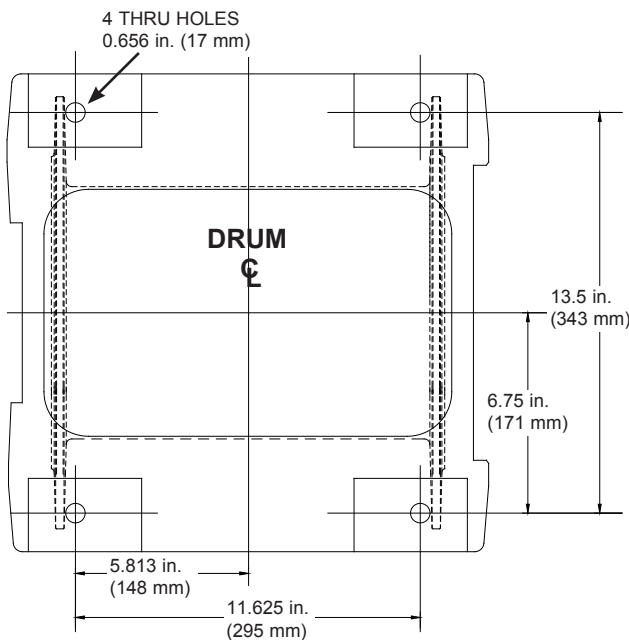

- A. Remove bearing support bolts.
- B. Rotate bearing support until vent plug is positioned correctly and bolt holes are aligned.
- C. Evenly tighten bolts to recommended torque.

3. When mounting the winch, use all four (4) mounting holes and grade 5 (8.8) or better bolts and nuts. Tighten to recommended torque.

5. Hydraulic lines and components that operate the winch should be of sufficient size to assure minimum back pressure at the winch. The motor manufacturer recommends that the back pressure not to exceed 100 PSI (690 kPa) for optimum motor seal life. 150 PSI (1,030 kPa) is the maximum allowable back pressure. The standard winch is supplied with the motor internally drained. If high back pressures are encountered, the motor may be externally drained directly to tank to improve motor seal life. For back pressures exceeding 150 PSI (1,030 kPa) consult BRADEN Service Department.

6. The winch should be mounted perpendicular to an imaginary line from the center of the drum to the first sheave to insure even spooling. Make certain the fleet angle does not exceed 1-1/2 degrees.

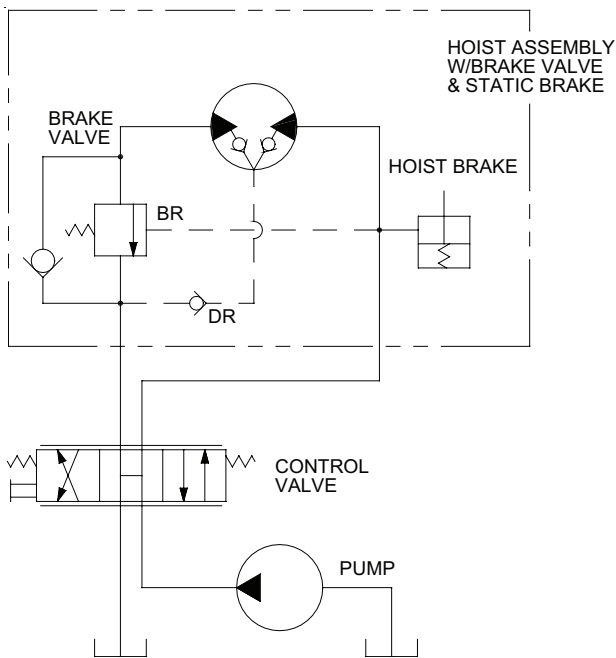

7. The winch directional control valve must be a three position four way valve with a motor spool such that when the valve is in the center position both work ports are open to tank (open center, open port).
8. High quality hydraulic oil is essential for satisfactory performance and long hydraulic system component life.

Oil having 150 to 330 SUS viscosity at 100°F (38°C) and viscosity index of 100 or greater will give good results under normal temperature conditions. The use of an oil having a high viscosity index will minimize cold-start trouble and reduce the length of warm-up periods. A high viscosity index will minimize changes in viscosity with corresponding changes in temperature.

Maximum cold weather start-up viscosity should not exceed 5000 SUS with a pour point at least 20° F (-7° C) lower than the minimum temperature.

Under continuous operating conditions, temperature of the oil at any point in the system must not exceed 180°F (82°C). Optimum oil temperature is generally considered to be 120°F-140°F (49°C-60°C).

In general terms; for continuous operation at ambient temperatures between 50°F and 110°F (10°C to 43°C) use SAE 20W; for continuous operation between 10°F and 90°F (-12°C to 32°C) use SAE 10W; for applications colder than 10°F (-12°C), contact the BRADEN Service Department. The use of multiviscosity oils is generally not recommended.

9. The hydraulic oil filter should have a 10 micron nominal rating and be full-flow type.



# WIRE ROPE INSTALLATION

## Correct Installation

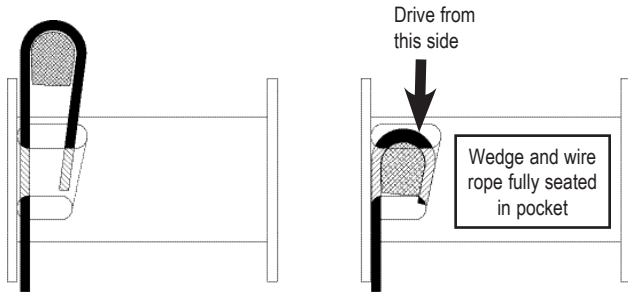

## Incorrect Installation

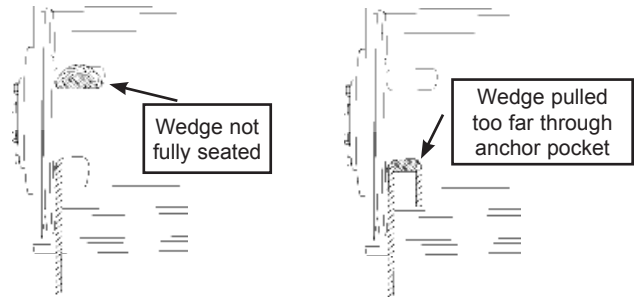

Take the free end of the wire rope and insert it through the small opening of the anchor pocket. Loop the wire rope and push the free end about 3/4 of the way back through the pocket. Install the wedge, then pull the slack out of the wire rope. The wedge will slip into the pocket and secure the wire rope into the drum.

The standard cable anchor or wedge shipped with the hoist, P/N 74780 will anchor 3/8- to 9/16-inch (10-14 mm) wire rope. For 1/4- to 5/16-inch (6-8 mm) wire rope, use P/N 24119. For 5/8- to 3/4-inch nylon or polyester rope use P/N 26095.

Maintain even tension of approximately one ton on the wire rope when spooling it onto the cable drum. DO NOT pinch wire rope through wood blocks to maintain tension as the wire rope may be permanently damaged. After the wire rope is installed on the hoist drum, pass the wire rope through all reeving and extend the boom to maximum length and height to reel out as much wire rope off the drum as possible until you reach the last five wraps. Apply a one ton weight to the hook and slowly reel in the wire rope while an assistant monitors the cable spooling at a safe distance from the hoist drum. If necessary, stop reeling in while the assistant packs the wire rope tightly. Resume spooling on the wire rope only after you are certain the assistant is a safe distance from the hoist drum and wire rope.

### ⚠ WARNING ⚠

The cable anchor or wedge is designed to hold rated load when installed correctly with properly prepared wire rope. Always maintain a minimum of five (5) complete wraps of wire rope on the drum. As a visual safety warning, paint the last five wraps of wire rope red. Failure to properly install the cable anchor or wedge and keep five wraps of wire rope on the drum may result in a dislodged cable anchor or wedge and loss of load control, property damage, and severe injury to personnel or death.

# PREVENTIVE MAINTENANCE

A regular program of preventive maintenance for your planetary winch is strongly recommended to minimize the need for emergency servicing and promote safe, reliable winch operation.

**NOTE:** The service intervals suggested in this manual will optimize component service life. The intervals may be gradually increased or decreased with experience of a particular lubricant and the recommendations of an independent oil analysis.

All service intervals are specified for operating hours of the prime mover.

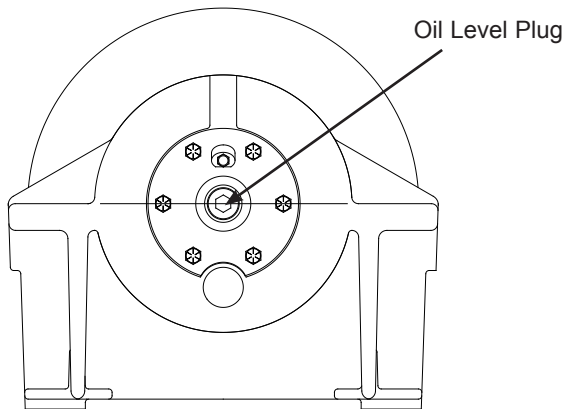

## 1. Oil Level

The gear oil level should be checked every 500 operating hours or three (3) months, whichever occurs first. To check the oil level, remove the large plug located in the center of the drum support. The oil should be level with the bottom of this opening. If additional oil is needed, refer to "Recommended Planetary Gear Oil."

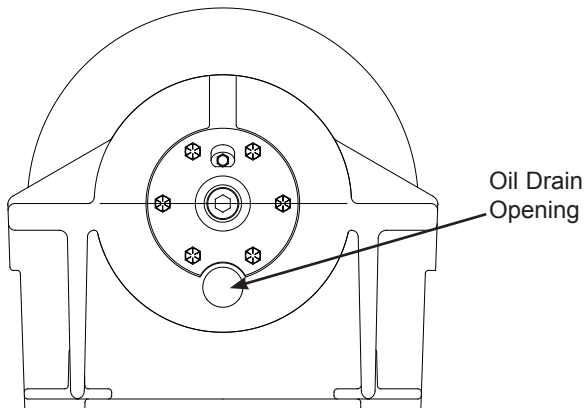

## 2. Oil Change

The gear oil should be changed after the first one hundred (100) hours of operation, then every 1,000 operating hours or six (6) months, whichever occurs first.

To drain the gear oil, align the drain plug in the drum with the hole in the support side of the base. Install a short piece of 1-inch pipe into the threaded drum port to prevent oil from draining onto winch base.

Insert a wrench through the 1-inch pipe and remove the drain plug. Install plug securely after oil has been drained. Refill with recommended planetary gear oil. Capacity is 4 U.S. pints (1.9L).

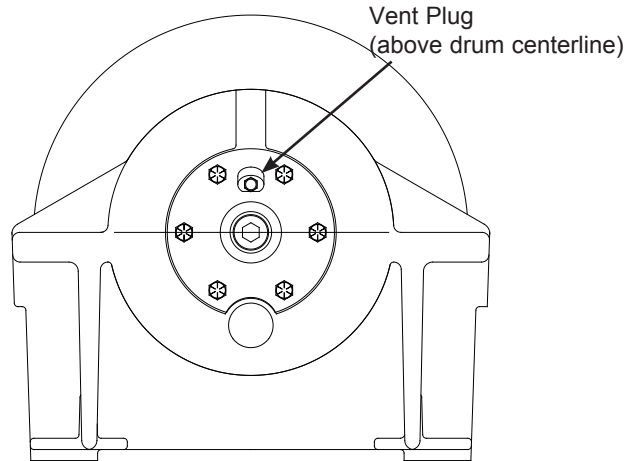

## 3. Vent Plug

The vent plug is located in the drum support as shown. It is important to keep this vent clean and unobstructed. Whenever gear oil is changed, remove vent plug, clean in solvent and reinstall.

Do not paint over the vent or replace with a solid plug.

## 4. Hydraulic System

The original filter element should be replaced after the first fifty (50) hours of operation, then every 500 operating hours or three (3) months, or in accordance with the equipment manufacturer's recommendations.

## 5. Wire Rope

Inspect entire length of wire rope according to wire rope manufacturers recommendations.

## 6. Mounting Bolts

Tighten all winch base mounting bolts to recommended torque after the first one hundred (100) hours of operation, then every 1000 operating hours or six (6) months, whichever occurs first.

## 7. Warm-up Procedures

A warm-up procedure is recommended at each start-up and is essential at ambient temperatures below +40°F (4°C).

The prime mover should be run at its lowest recommended RPM with the hydraulic winch control valve in neutral allowing sufficient time to warm up the system. The winch should then be operated at low speeds, forward and reverse, several times to prime all lines with warm hydraulic oil, and to circulate gear lubricant through the planetary gear sets.

the winch should be completely disassembled to inspect for excessive wear every 2,000 hours of operation or 12 months, whichever occurs first.

### Recommended Planetary Gear Oil

Field experience, supported by extensive engineering tests, indicates the use of the proper planetary gear oil is essential to reliable and safe operation of the brake clutch and obtaining long gear train life.

For simplicity, BRADEN has listed one (1) readily available product in each temperature range which has been tested and found to meet our specifications. This is not to say that other lubricant brands would not perform equally as well.

If the following lubricant brands are not available in your area, make certain your lubricant vendor supplies you with oil that is equivalent to those products listed below.

BRADEN planetary winches are factory filled with Exxon Spartan 150 or equivalent AGMA 4EP gear oil.

**⚠ WARNING ⚠**

Failure to properly warm up the winch, particularly under low ambient temperature conditions, may result in temporary brake slippage due to high back pressures attempting to release the brake, which could result in property damage, severe personal injury, or death.

### 8. Oil Analysis

We recommend an oil analysis be conducted on the gear oil at regular intervals. Wear metals should be monitored for early detection of problems and lubricant effectivity. In severe applications,

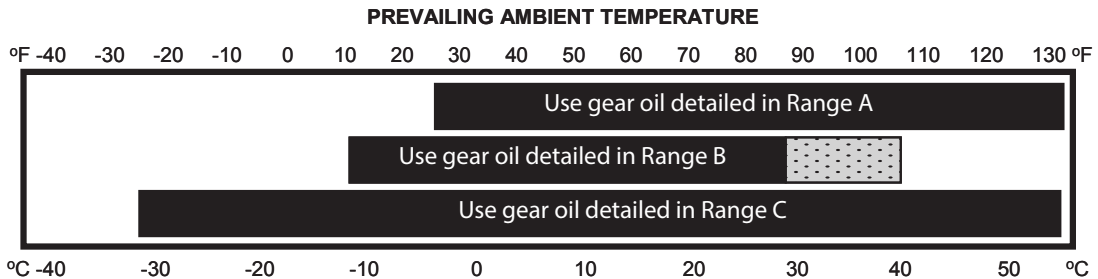

SHADED TEMPERATURE RANGE IN THE CHART ABOVE NOT RECOMMENDED FOR SEVERE APPLICATIONS SUCH AS SUSTAINED FAST DUTY CYCLES OR FREQUENT WINCHING.

Winches are factory filled with Mobilgear 600 XP 150 or equivalent. Consult your oil supplier for other equivalent oils if required.

	Mobil	Shell	Chevron	Texaco
Range A	Mobilgear 600 XP 220	Omala S2 G 220	Gear Compounds EP 220	Meropa 220
Range B	Mobilgear 600 XP 150	Omala S2 G 150	Gear Compounds EP 150	Meropa 150
Range C	Mobilgear SHC 150	Omala S4 GX 150		

### 071 MOTOR

**⚠ WARNING ⚠**

The brake valve cartridge is factory set and normally requires no further adjustment. The brake valve can be manually piloted open by its adjusting screw. Manually opening the brake valve could cause internal winch damage and may cause loss of load control during lowering operations which may result in property damage, personal injury, or death.

The brake valve cartridge may be unique in that turning the adjusting screw in, clockwise, lowers the release pressure. If it is determined a brake valve adjustment is required, the entire brake valve should be replaced.

The brake valve cartridge is easily removed from the valve block for cleaning, inspection or replacement, but is not designed to be disassembled in the field. In the event it has been determined the brake valve should be disassembled, the entire cartridge should be replaced.

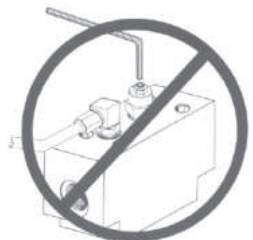

# TROUBLESHOOTING

TROUBLE	PROBABLE CAUSE	REMEDY
<p style="text-align: center;"><b>A</b></p> <p>The winch will not lower the load or not lower the load smoothly.</p>	<p>1. The problem could be a plugged or loose pilot orifice. The pilot orifice is a small pipe plug with a hole drilled through it, located behind the pilot port fitting on the brake valve. If it becomes plugged, it will prevent the pilot pressure, from the manifold, from opening the brake valve. If it becomes loose, it will allow an unregulated amount of oil in to operate the brake valve which causes erratic brake valve operation.</p> <p>2. The friction brake may not be releasing as a result of a defective brake cylinder seal.</p> <p><b>NOTE:</b> If the brake cylinder seal is defective you will usually find oil leaking from the winch vent plug.</p> <p>3. Friction brake will not release as a result of damaged brake discs.</p>	<p>Remove the pilot hose and fitting from the brake valve, then use a 5/32-inch Allen wrench to remove the pilot orifice. The diameter of the orifice is approximately .020 inch. Clean and install the pilot orifice tightly in the brake valve.</p> <p>Check brake cylinder seal as follows:</p> <p>A. Disconnect the swivel tee from the brake release port. Connect a hand pump with accurate 0-2000 PSI gauge and shut-off valve to the —4 JIC fitting in the brake release port.</p> <p>B. Apply 1000 PSI to the brake. Close shut-off valve and let stand for five (5) minutes.</p> <p>C. If there is any loss of pressure in five (5) minutes, the brake cylinder should be disassembled for inspection of the sealing surfaces and replacement of the seals. Refer to “Motor Support — Brake Cylinder Service.”</p> <p>Disassemble brake to inspect brake discs. Check stack-up height as described in “Motor Support — Brake Cylinder Service.”</p>
<p style="text-align: center;"><b>B</b></p> <p>Oil leaks from vent plug.</p>	<p>1. Same as A2.</p> <p>2. Motor seal may be defective as a result of high system back pressure or contaminated oil.</p>	<p>Same as A2.</p> <p>System back pressure must not exceed 150 PSI. Inspect hydraulic system for a restriction in the return line from the control valve to the reservoir. Be sure control valve and plumbing is properly sized to winch motor.</p> <p>Oil analysis may indicate contamination has worn motor shaft and seal. Thoroughly flush entire hydraulic system and install new filters and oil. Install new motor seal.</p>

TROUBLE	PROBABLE CAUSE	REMEDY
<p style="text-align: center;"><b>C</b></p> <p>The brake will not hold a load with the control lever in neutral.</p>	<ol style="list-style-type: none"> <li>1. Excessive system back pressure acting on the brake release port.</li> <li>2. Friction brake will not hold due to worn or damaged brake discs.</li> <li>3. Brake clutch is slipping.</li> </ol>	<p>The same as Remedy 2 of Trouble B2.</p> <p>Same as Remedy 3 of Trouble A3.</p> <p>Improper planetary gear oil may cause the brake clutch to slip. Drain old gear oil and flush winch with solvent. Thoroughly drain solvent and refill winch with recommended planetary gear oil listed in "Preventive Maintenance."</p> <p>Brake clutch may be damaged or worn. Disassemble and inspect brake clutch as described in "Brake Clutch Service."</p>
<p style="text-align: center;"><b>D</b></p> <p>The winch will not hoist the rated load.</p>	<ol style="list-style-type: none"> <li>1. The winch may be mounted on an uneven or flexible surface which causes distortion of the winch base and binding of the gear train. Binding in the gear train will absorb horsepower needed to hoist the rated load and cause heat.</li> <li>2. System relief valve may be set too low. Relief valve needs adjustment or repair</li> <li>3. Be certain hydraulic system temperature is not more than 180°F. Excessive hydraulic oil temperatures increase motor internal leakage and reduce motor performance.</li> <li>4. Winch line pull rating is based on first layer of wire rope.</li> <li>5. Rigging and sheaves not operating efficiently.</li> </ol>	<p>Reinforce mounting surface.</p> <p>If necessary, use shim stock to level winch. Refer to "Winch Installation."</p> <p>First loosen, then evenly retighten all winch mounting bolts to recommended torque.</p> <p>Check relief pressure as follows:</p> <ol style="list-style-type: none"> <li>A. Install an accurate 0-4000 PSI (27,580 kPa) gauge into the inlet port of the brake valve.</li> <li>B. Apply a stall pull load on the winch while monitoring pressure.</li> <li>C. Compare gauge reading to winch specifications. Adjust relief valve as required.</li> </ol> <p><b>NOTE:</b> If pressure does not increase in proportion to adjustment, relief valve may be contaminated or worn out. In either case, the relief valve may require disassembly or replacement.</p> <p>Same as remedies for Trouble D1 and D2.</p> <p>Same as remedies for Trouble E2.</p>

TROUBLE	PROBABLE CAUSE	REMEDY
<p><b>TROUBLE "D"</b>  <b>CONTINUED FROM</b>  <b>PREVIOUS PAGE</b></p>	<p>4. Winch line pull rating is based on 1st layer of wire rope.</p> <p>5. Rigging and sheaves not operating efficiently.</p>	<p>Refer to winch performance charts for additional information.</p> <p>Perform rigging service as recommended by crane manufacturer.</p>
<p><b>E</b></p> <p>The winch runs hot.</p>	<p>1. Same as D1.</p> <p>2. Be certain that the hydraulic system temperature is not more than 180°F. Excessive hydraulic oil temperatures may be caused by:</p> <p>A. Plugged heat exchanger.</p> <p>B. Too low or too high oil level in hydraulic reservoir.</p> <p>C. Same as D2.</p> <p>D. Hydraulic pump not operating efficiently.</p> <p>3. Excessively worn or damaged internal winch parts.</p>	<p>Same as remedies for Trouble D1.</p> <p>Thoroughly clean exterior and flush interior.</p> <p>Fill/drain to proper level.</p> <p>Same as remedies for Trouble D2.</p> <p>Prime mover low on horsepower or RPM Tune/adjust prime mover.</p> <p>Check suction line for damage.</p> <p>If pump is belt driven, belts are slipping. Replace/tighten belts.</p> <p>Pump worn. Replace pump.</p> <p>Disassemble winch to inspect/replace worn parts.</p>

TROUBLE	PROBABLE CAUSE	REMEDY
<p style="text-align: center;"><b>F</b></p> <p>Winch “chatters” while raising rated load.</p>	<ol style="list-style-type: none"> <li>1. Same as D2.</li> <li>2. Hydraulic oil flow to motor may be too low.</li> <li>3. Controls being operated too quickly.</li> </ol>	<p>Same as remedies for Trouble D2.</p> <p>Same as remedies for Trouble E2.</p> <p>Conduct operator training as required.</p>
<p style="text-align: center;"><b>G</b></p> <p>The wire rope does not spool smoothly on the drum.</p>	<ol style="list-style-type: none"> <li>1. The winch may be mounted too close to the main sheave, causing the fleet angle to be more than 1-1/2 degrees.</li> <li>2. The winch may not be mounted perpendicular to an imaginary line between the center of the cable drum and the first sheave.</li> <li>3. Could possibly be using the wrong lay rope. There is a distinct advantage in applying rope of the proper direction of lay. When the load is slacked off, the several coils on the drum will stay closer together and maintain an even layer. If rope of improper lay is used, the coils will spread apart each time the load is removed. Then, when winding is resumed, the rope has a tendency to crisscross and overlap on the drum. The result is apt to be a flattened and crushed rope.</li> <li>4. The winch may have been overloaded, causing permanent set in the wire rope.</li> </ol>	<p>Check mounting distance and fleet angle. Reposition winch as required.</p> <p>Refer to “Winch Installation.”</p> <p>Consult wire rope manufacturer for recommendation of wire rope that best suits your application.</p> <p>Replace wire rope and conduct operator/rigger training as required.</p>

# DISASSEMBLY OF WINCH

## SERVICE PRECAUTIONS

- Before any part is removed from the winch, all service instructions should be read and understood.
- Work in a clean, dust free area as cleanliness is of utmost importance when servicing hydraulic equipment.
- Inspect all replacement parts, prior to installation, to detect any damage which might have occurred in shipment.
- Use only genuine BRADEN replacement parts for optimum results. Never reuse expendable parts such as oil seals and O-rings.
- Inspect all machined surfaces for excessive wear or damage . . . before reassembly operations are begun.
- Lubricate all O-rings and oil seals with gear oil prior to installation.
- Use a sealing compound on the outside surface of oil seals and a light coat of thread sealing compound on pipe threads. Avoid getting thread compound inside parts or passages which conduct oil.
- Thoroughly clean all parts in a good grade of non-flammable safety solvent. Wear protective clothing as required.

After troubleshooting the winch and its hydraulic system as covered in the "Troubleshooting" section, and the problem is determined to be in the winch, use the following procedure to disassemble the winch.

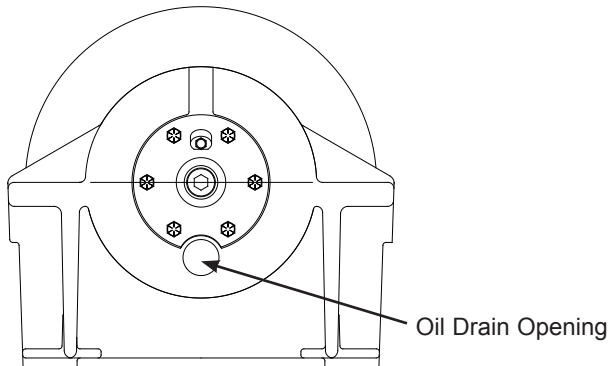

1. Remove the wire rope from the winch drum and align the drain hole in the drum with a hole in the support side plate before removing the hoses and mounting bolts. After the winch is removed from its mounting, thoroughly clean the outside surfaces. To drain the oil, install a short piece of 1-inch pipe in the larger threads of the drain hole. If necessary, insert a bar into the anchor pocket and manually rotate the drum in the direction to hoist a load until the drain holes are aligned.

2. Use a 5/16-inch Allen wrench to remove the drain plug through the pipe. Drain the oil into a suitable container and dispose of used oil in an environmentally friendly manner.

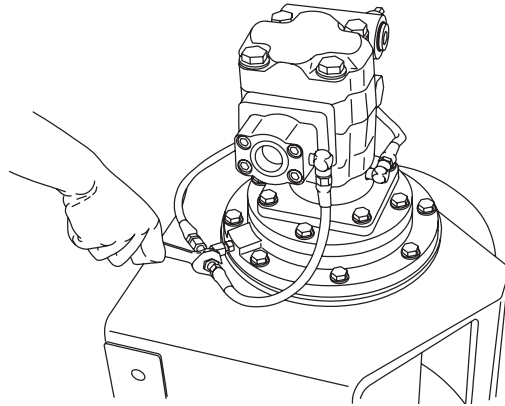

3. Begin disassembly by removing the oil level plug and standing the winch on the bearing support end. Tag and remove the hydraulic hoses that connect the brake valve and manifold to the brake cylinder.
4. Remove the capscrews securing the motor, and lift the motor off the winch. Remove and discard the O-ring installed on the pilot of the motor.

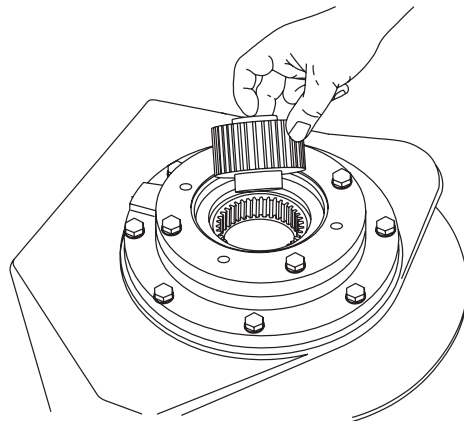

5. Remove the brake clutch assembly from the motor support. Refer to "Brake Clutch Service" for additional information.



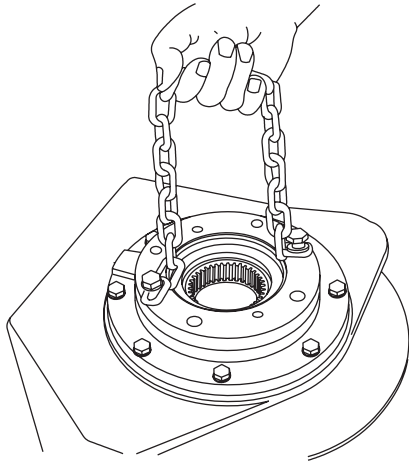

6. Remove the brake cylinder capscrews and install two (2) capscrews and a short piece of chain into the motor mounting bolt holes. Using the chain as a handle, lift the brake cylinder assembly out of the drum and base, being careful to avoid damaging the sealing and bearing surfaces. Refer to “Motor Support — Brake Cylinder Service” for additional information.

7. (BG8A ONLY) Remove the drum closure. Remove and discard the O-ring from the inside of the drum. Remove the seal from the drum closure.  
(BG8B) The seal is mounted in the drum. Remove the seal and drum closure from the drum.

8. Clean and inspect the bearing in the drum closure and replace if required.

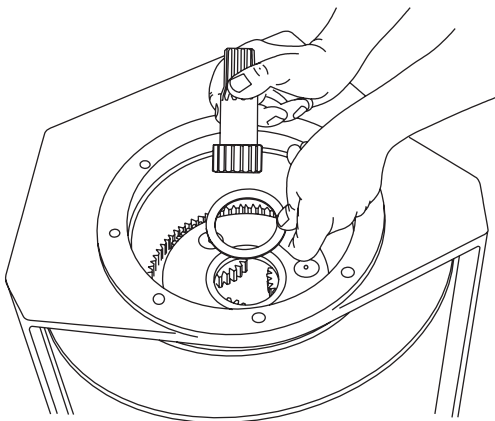

9. Remove the primary sun gear and thrust washer from the primary planet carrier.

**NOTE:** 23:1 gear ratio winches have a sun gear adapter in addition to the sun gear shaft.

10. Remove the primary planet carrier from the drum. Refer to “Planet Carrier Service” for additional information.

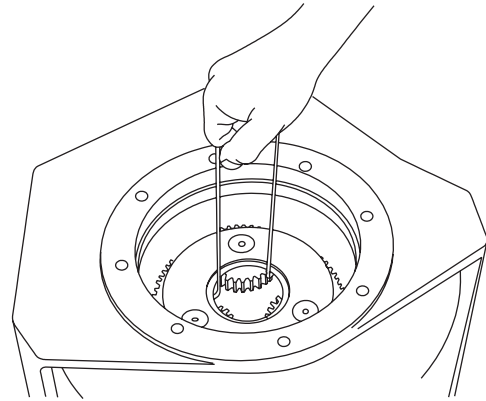

11. Remove the output sun gear and thrust washer from the output planet carrier.

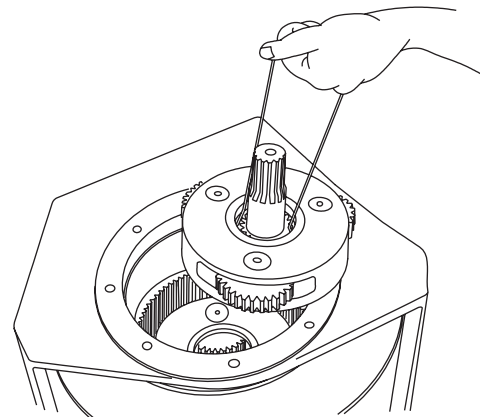

12. Remove the output planet carrier from the drum. Refer to “Planet Carrier Service” for additional information.

13. Remove snap ring from bearing support.

14. Stand winch on motor end with bearing support up; then remove bearing support capscrews and bearing support being careful to avoid damaging the sealing and bearing surfaces.

15. Slide drum out of base onto a work bench and remove seal and bearing from support end.

16. Thoroughly clean and inspect drum and base. Check ring gear (machined into inside surface of drum) teeth for nicks, spalling or excessive wear. Replace if wear is greater than 0.015 inch (0.4 mm) when compared to unworn area of teeth.

# PLANETARY CARRIER SERVICE

## OUTPUT PLANET CARRIER DISASSEMBLY

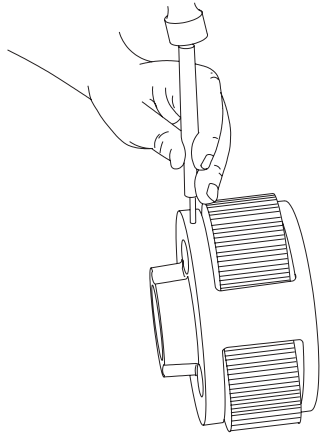

1. Remove the planet gears by driving the roll pins into the center of the planet shafts.

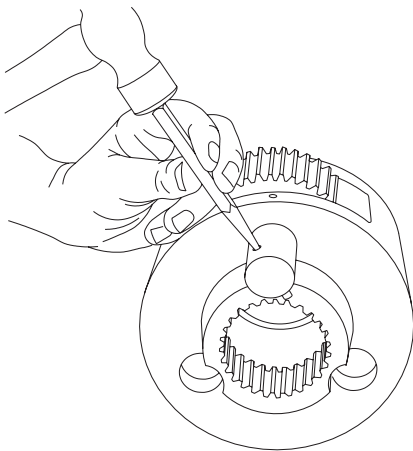

2. Use a punch to drive the roll pins from the planet shafts. Do not reuse the roll pins.

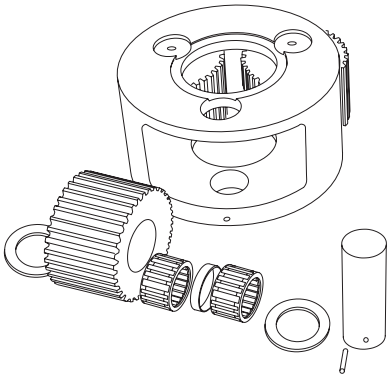

3. Now you can remove the planet shafts, bearings, spacer, thrust washers and gears. Thoroughly clean all parts and inspect for damage and wear. The bearing rollers should not exhibit any irregularities. If the rollers show any sign of spalling, corrosion,

discoloration, material displacement or abnormal wear, the bearing should be replaced. Likewise, the cage should be inspected for unusual wear or deformation, particularly the cage bars. If there is any damage that will impair the cage's ability to separate, retain and guide the rollers properly, the bearing should be replaced. The thrust washer contact areas should be free from any surface irregularities that may cause abrasions or friction. The gears and shafts should be inspected for abnormal wear or pitting. Replace if necessary.

## ASSEMBLY

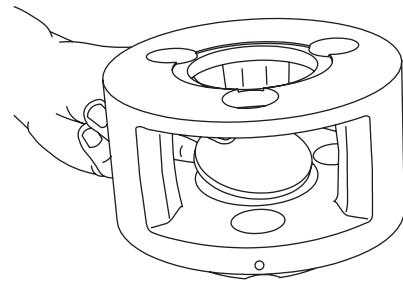

1. Place the output planet carrier on workbench with splined coupling side down. Install output thrust plate in center of carrier.

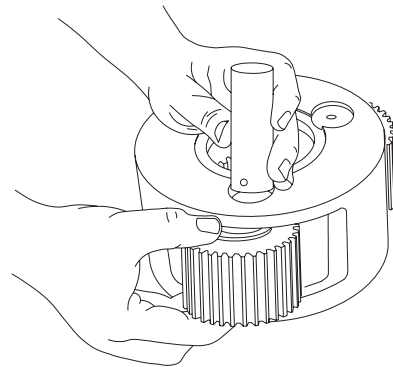

2. Insert two (2) bearings and a bearing spacer into a gear with the spacer between the bearings. Place a thrust washer on each side of the gear and position in a carrier opening. Slide the shaft through the carrier, thrust washer, bearing-gear sub-assembly and remaining thrust washer.

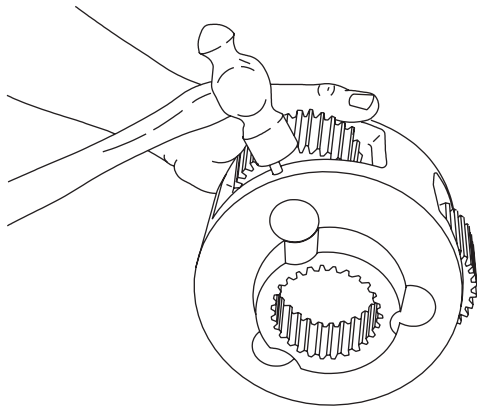

3. Carefully align the pin hole in the carrier with the hole in the planet gear shaft and drive the roll pin into place. Always use NEW roll pins.

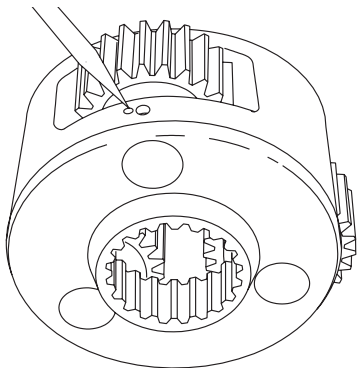

4. Note that the roll pin is slightly recessed in the carrier when properly installed. With a center punch, stake the carrier next to the pin hole as shown. This will distort the hole so the pin will not back out. Repeat these steps for each of the three planet gears.

## PRIMARY PLANET CARRIER

1. To service the primary planet carrier, the steps are the same as for the output carrier except there is only one bearing for each gear and no bearing spacer.

**i** **NOTE:** All BG8 winches have a round thrust plate between the primary and output sun gears. In winches with a 23:1 ratio, the plate is not contained in the primary planet carrier. In all other ratios, the thrust plate is captive in the carrier assembly.

# MOTOR SUPPORT — BRAKE CYLINDER SERVICE

**NOTE:** Starting late 2000, BRADEN changed the steel brake separator discs from a splined tooth design to a lobed design. This required a change to the motor support and brake cylinder and the addition of a spring spacer. A winch with the lobed discs can be identified by a machined groove on the outside diameter of the motor support. When replacing steel brake discs, the motor support or brake cylinder, care must be taken to properly identify the correct parts. Splined discs, and their mating motor support and brake cylinder will remain available as spare parts.

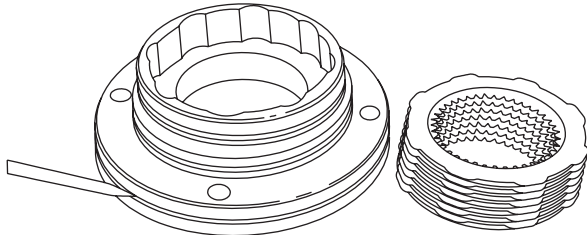

New lobed steel brake separator plates and motor support. Note groove on outside diameter of motor support.

Although most illustrations in this section show splined discs, all procedures are the same except where specifically noted.

## DISASSEMBLY

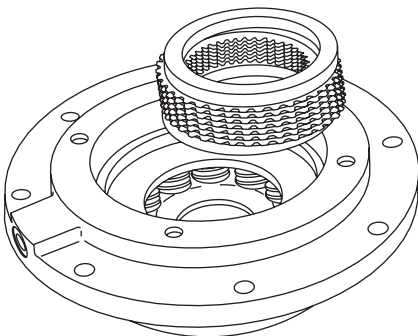

1. After removing the motor support and brake clutch assembly, continue brake cylinder disassembly by removing the spacers, friction brake discs and steel brake discs.

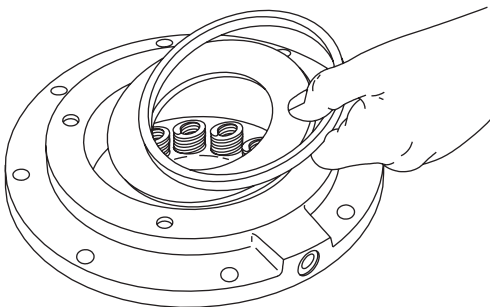

2. Remove the piston backup ring and the pressure plate.

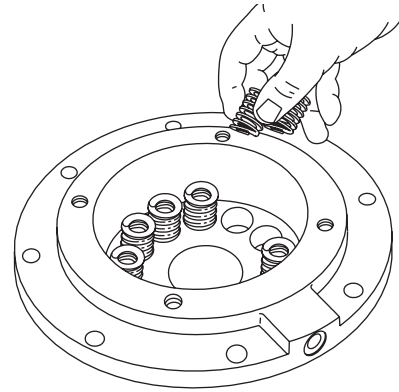

3. Remove the brake springs.

## CLEAN AND INSPECT

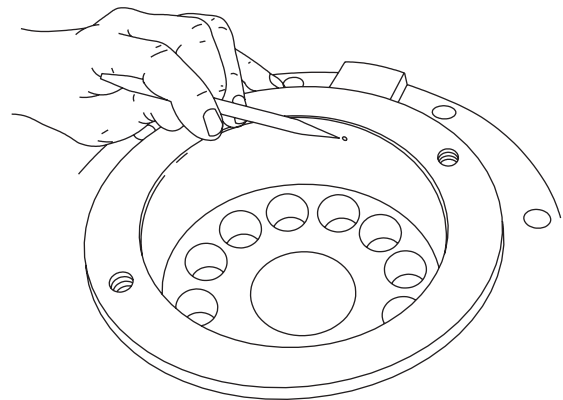

1. Thoroughly clean and inspect all parts at this time. Check brake piston sealing surfaces on brake cylinder and motor support. Be sure brake release port is free of contamination.

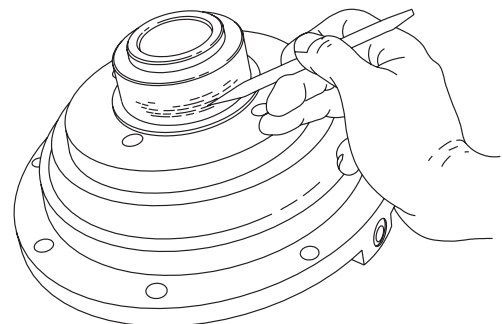

2. Check oil seal and bearing surfaces on brake cylinder for damage or wear.

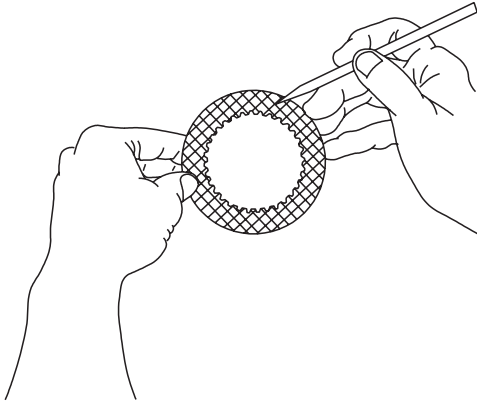

3. Place friction brake disc on flat surface and check for distortion with a straight edge. Friction material should appear even across entire surface with groove pattern visible. Replace friction disc if splines are worn to a point, disc is distorted, friction material is worn unevenly, or groove pattern is worn away.
4. Place steel brake disc on flat surface and check for distortion with a straight edge. Check surface for signs of material transfer or heat. Replace steel disc if splines are worn to a point, or if disc is distorted or heat discolored.

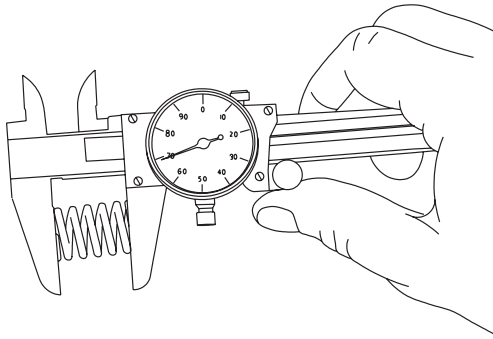

5. Check brake spring free length; minimum free length is:

Model	Spring minimum free length
BG8A	1-3/16 inch (30.2 mm)
BG8B	15/16 inch (23.81 mm)

Check springs for any sign of cracking or failure. If a brake spring must be replaced for any reason, then ALL brake springs must be replaced.

**⚠ CAUTION ⚠**

Failure to replace brake springs as a set may result in uneven brake application pressure and repeated brake spring failure.

**ASSEMBLY**

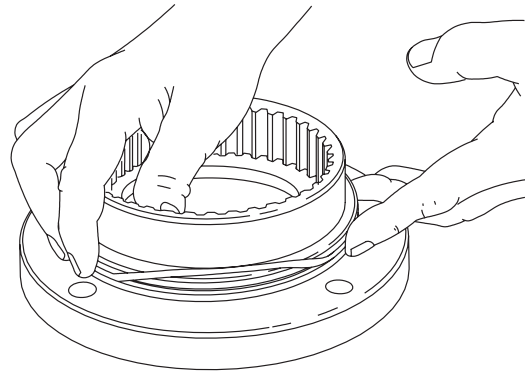

1. Begin assembly by placing motor support on workbench with motor mounting surface down. Install new O-ring and backup ring as shown.

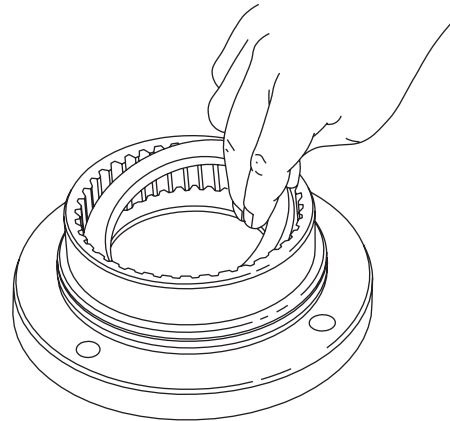

**FOR BG8A ONLY**

2. Install a 3/8-inch (9.5 mm) thick spacer into the motor support.

**NOTE:** The BG8B with lobed brake discs does not use this spacer.

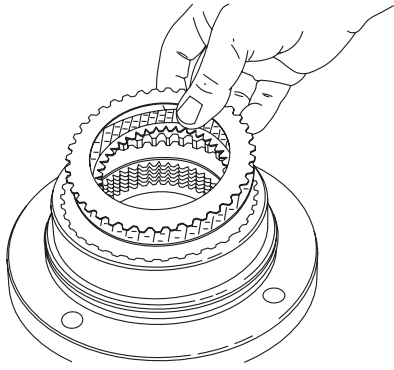

3. Insert first, a steel brake disc against the spacer followed by a friction brake disc then alternate steel and friction discs until all discs have been installed. Finish with a steel brake disc on top.

**NOTE:** It is a good practice to prelubricate the discs in light motor oil prior to assembly.

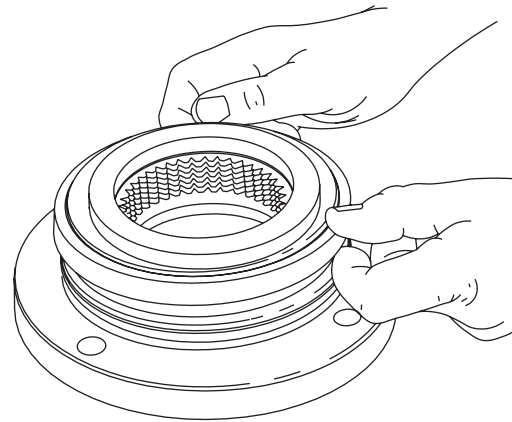

6. Lubricate the brake piston seal and motor support sealing surface with petroleum jelly or hydraulic oil. Install new piston seal to motor support, seal lip down.

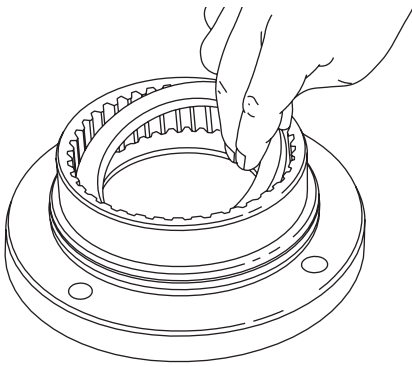

4. Install **two** 1/8-inch (3.2 mm) thick brake spacers on top of the last steel brake disc. Install the remaining 3/8-inch (9.5 mm) thick spacer on top of the brake spacer discs.

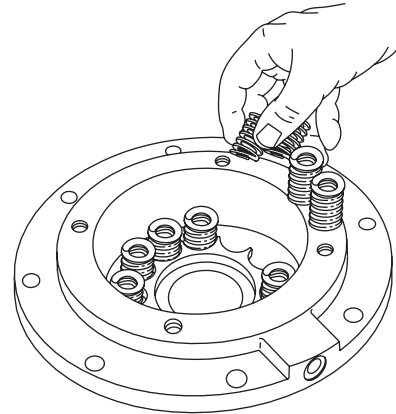

7. Install brake springs into brake cylinder.

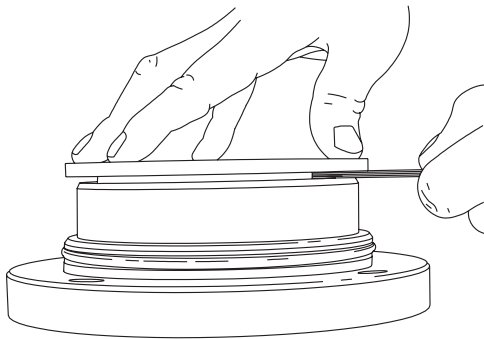

5. To check brake stack height, place pressure plate on top of brake spacer. Hold pressure plate down firmly by hand and measure clearance in three places between motor support and pressure plate. Average gap must measure between .153 inch (3.99 mm) maximum and .080 inch (2.0 mm) minimum. If the gap exceeds the maximum limit, there are too many brake discs in stack-up or the discs are distorted. If the gap is less than the minimum, there are too few discs in stack-up or the discs are worn out. When stack height is correct, remove pressure plate and continue assembly.

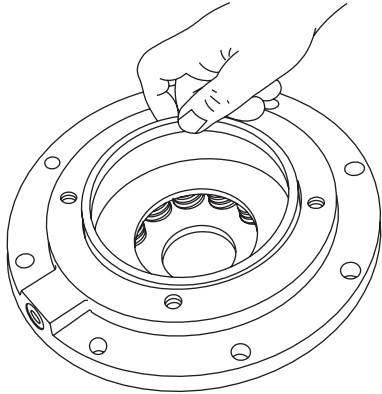

8. Install pressure plate into brake cylinder followed by the piston backup ring. The close-fitting piston backup ring may be depressed slightly to one side to lodge the backup ring in the brake cylinder bore and temporarily hold the pressure plate and springs in place while you lower the brake cylinder over the motor support.

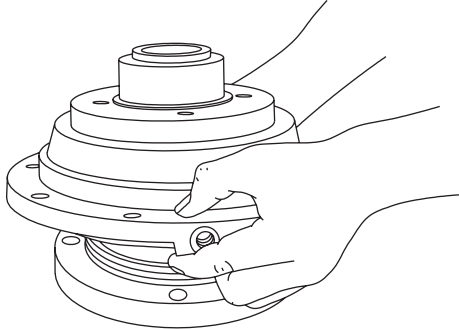

9. Apply petroleum jelly to the entire sealing surface of the brake cylinder and to the piston seal. Install the brake cylinder over the motor support being careful to avoid damaging the piston seal or motor support O-ring. (A press may be necessary to avoid cocking the brake cylinder during installation.)
10. Install motor support capscrews and tighten evenly to recommended torque.

## BRAKE CYLINDER PRESSURE TEST

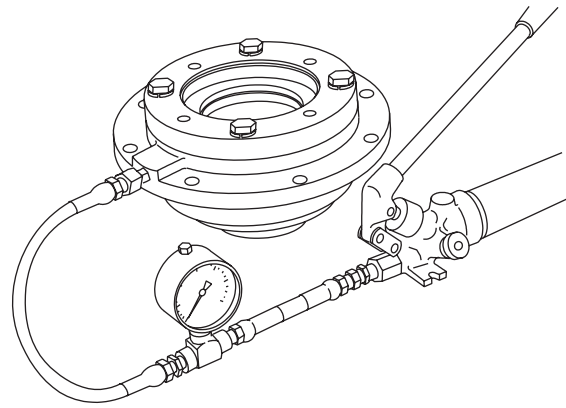

1. Install the -4 JIC fitting into the brake release port. Connect a hand pump with accurate 0-2000 PSI (0-13,800 kPa) gauge and shut-off valve to this fitting. Apply 1000 PSI (6,900 kPa) to the brake. Close shut-off valve and let stand for five (5) minutes. If there is any loss of pressure in five (5) minutes, the brake cylinder should be disassembled for inspection of the sealing surfaces and brake piston seal.
2. WHILE PRESSURE IS APPLIED AND THE BRAKE RELEASED, install the brake clutch assembly in the brake pack. Turn the clutch back and forth as you align the outer race splines with the brake disc splines.
3. Release the pressure on the brake cylinder then remove the brake clutch assembly. The brake cylinder assembly is now complete and ready to be installed in the winch.

# BRAKE CLUTCH SERVICE

## DISASSEMBLY

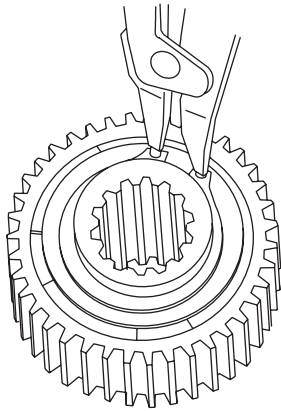

1. Remove the snap ring and sprag bushing retainer from one end only.

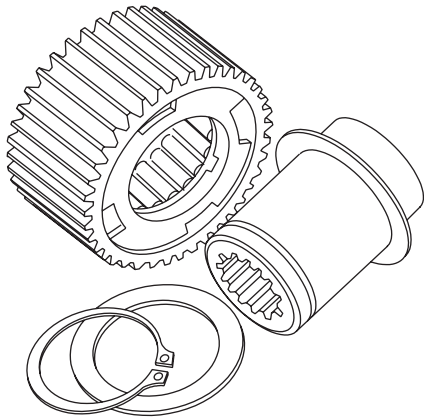

2. Pull the inner race out. Examine the race for scoring, wear or indentations caused by the sprag cams.

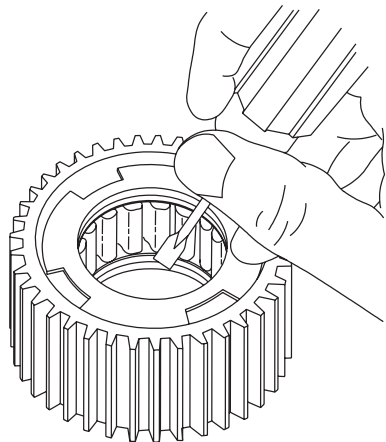

3. Use a screwdriver and mallet to remove the sprag bushing from one end of the outer race. There are four special cut-outs in the bushing for this purpose. Be careful not to damage the bushing inside surface. If a bushing's inside surface is damaged or shows wear, replace it.

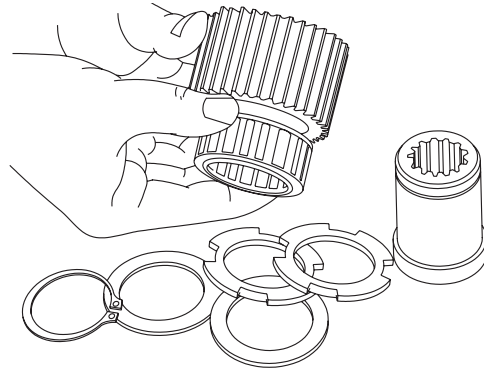

4. Next, slide the sprag clutch out, inspect the sprag clutch closely for abnormal wear, cracks, pitting or corrosion. Check small clips for breakage or bright spots; the signs of excessive wear. Unless the outer race or remaining sprag bushing is damaged or shows excessive wear, there is no need for further disassembly. If disassembly is necessary, remove the bushing according to the procedure covered in Step 3. All brake clutch assembly parts should be thoroughly cleaned and inspected before assembly.

### ⚠ WARNING ⚠

The polished surfaces of races and sprag cams must be perfectly smooth to ensure positive engagement of the clutch. The slightest defect may reduce brake clutch effectiveness, which could result in property damage, severe personal injury, or death. The entire brake clutch assembly must be replaced if inner race, outer race, and/or sprag cams are defective.

## ASSEMBLY

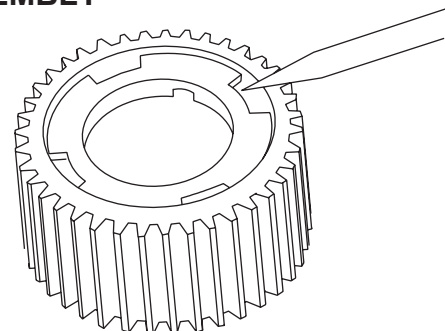

1. Press a sprag bushing into the outer race, using a mechanical or hydraulic press. A flat plate of approximately the same diameter as the bushing flange outside diameter should be placed between the press and bushing during assembly to protect the bushing. Be certain the bushing flange is against the shoulder in the outer race.



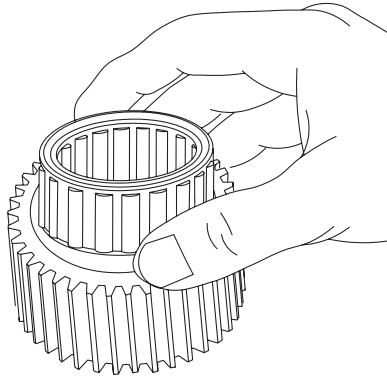

2. Turn the assembly over and install the sprag clutch in the bore of the outer race.
3. Press the remaining bushing into the race. Again, make sure the bushing is against the shoulder.

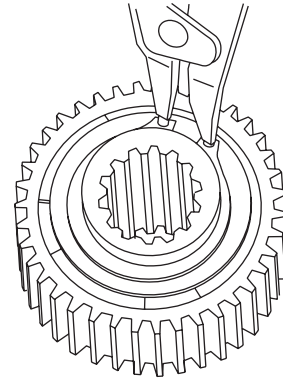

6. Turn the assembly over with the snap ring down. Install the second retainer and snap ring. Make certain the snap ring is seated in the groove properly.

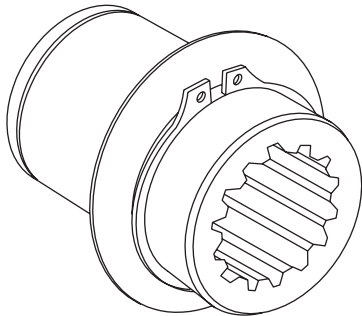

4. Next, install a sprag bushing retainer, then a snap ring on the inner race. Be sure the snap ring is seated in the snap ring groove.

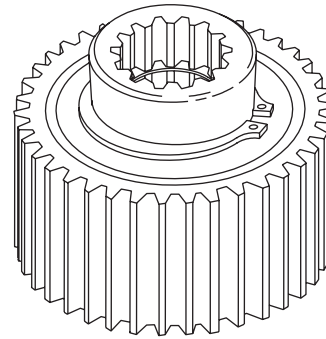

7. This is a completed brake clutch assembly.

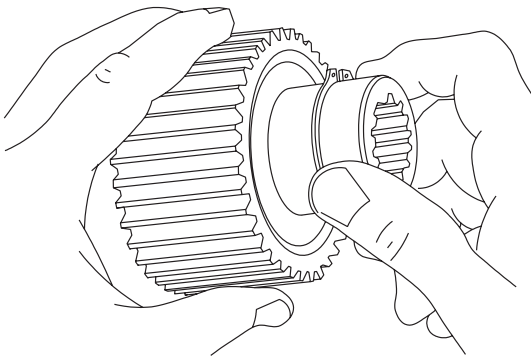

5. Slide the inner race through the bushings and sprag clutch (the race will have to be rotated in the free-wheeling direction to start it through the sprag clutch). If the inner race will not go through the bushings, the bushings have probably been damaged and should be replaced.

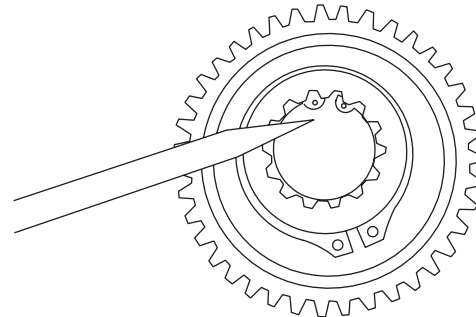

**⚠ WARNING ⚠**

Be certain the snap ring is seated in the groove in the splined bore of the inner race. This snap ring will keep the brake clutch assembly correctly positioned in the center of the friction brake pack. Binding of the brake or brake failure may occur if this snap ring is omitted.

# WINCH ASSEMBLY

1. Place winch base on side with bearing support end up.
2. Install a new bearing in the drum if replacement is necessary. Apply a nonhardening sealant on the outside diameter of a new seal. Install the spring side of the seal toward the bearing, then press into the drum, using a flat plate to avoid distortion. Be sure drain plug is installed securely.

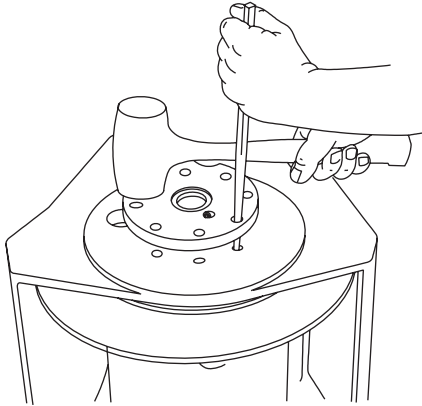

3. Center the drum in the opening of the base. Lubricate the bearing support with petroleum jelly or gear oil and install in base and drum.

VENT PLUG  
ABOVE CENTERLINE

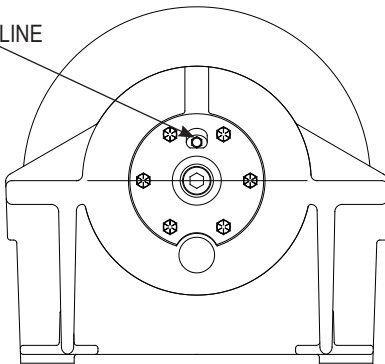

## ⚠ CAUTION ⚠

Be sure the vent plug is located above the horizontal centerline for the intended application. Oil leakage may occur if vent is positioned incorrectly.

4. Tighten the bearing support capscrews to the recommended torque.

5. Stand winch on bearing support end and install snap ring on bearing support.

## ⚠ CAUTION ⚠

This snap ring will keep the output planet carrier correctly positioned in the winch. Gear train damage may occur if this snap ring is omitted.

6. Install the output sun gear and thrust washer into the output planet carrier.

**i** TIP: 2 pieces of stiff wire with an L-shaped hook on one end can be used to lower the planet carrier assemblies into the drum.

7. Install the output planet carrier into the drum while meshing the planet gears with the ring gear and the planet housing with the bearing support.

8. Install the primary sun gear and thrust washer into the primary planet carrier.

**i** NOTE: 23:1 gear ratio winches have a sun gear adapter in addition to sun gear shaft. The thrust plate between the primary and output sun gears is not captive within the carrier assembly. Apply a small amount of oil soluble grease or petroleum jelly to the thrust plate and center it on the output sun gear before installing the primary planet carrier assembly.

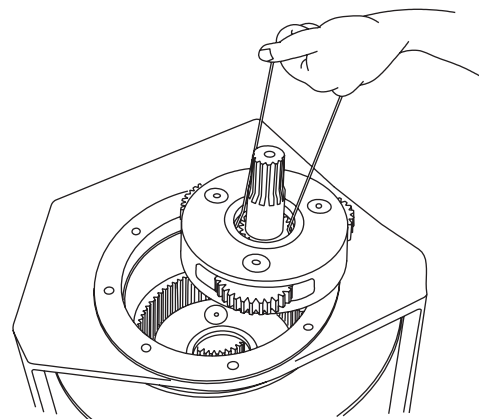

9. Install the primary planet carrier, meshing the planet gears with the ring gear and the planet housing with the output sun gear.

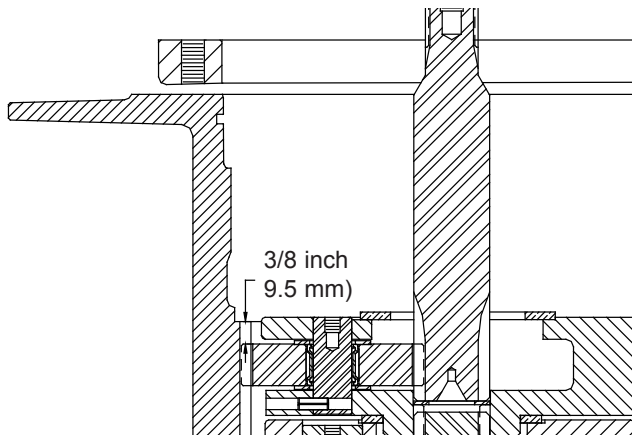

**⚠ CAUTION ⚠**

When all components are correctly installed, the primary planet gears will be approximately 3/8 inch (9.5 mm) below the ring gear, as shown above. Binding and damage to the gear train may result if one or more of the thrust washers is incorrectly installed.

- 10. Install a new bearing in the drum closure if required. **BG8A ONLY:** Apply a nonhardening sealant on the outside surface of a new oil seal. Install with spring side of the seal toward the bearing, using a flat plate to avoid distortion. Install a new O-ring in the drum.
- 11. Lubricate the drum opening with petroleum jelly or gear oil and install the drum closure into the drum. **BG8B ONLY:** Apply a nonhardening sealant on the outside surface of a new oil seal. Install with spring side of the seal toward the drum closure, using a flat plate to avoid distortion.
- 12. Lubricate the pilot, oil seal and bearing surfaces of the brake cylinder and carefully install brake cylinder into base and drum. Be careful that the brake cylinder pilot fits into the thrust washer on the primary planet carrier. When correctly installed, the brake cylinder will fit against the winch base.

- 13. Install and tighten brake cylinder capscrews and lockwashers. Tighten to recommended torque.
- 14. Install the brake clutch assembly.  
When installed correctly, the cam should turn freely in the opposite direction the drum turns to pull wire rope in. An easy way to check the rotation is to hold the outer race in one hand, and rotate the cam.
- 15. If the brake discs are misaligned, preventing the installation of the clutch, apply 750-1000 PSI (5170-6900 kPa) to the brake release port with a hand pump. The brake discs will move freely with the brake released, permitting alignment of the discs, brake clutch and input sun gear.
- 16. Install a new O-ring on the motor pilot then lubricate with petroleum jelly or gear oil. Engage the motor shaft with the inside race of the brake clutch and lower motor into place. Install and tighten capscrews to recommended torque.
- 17. Install the hoses and fittings to the brake cylinder release port, manifold and brake valve.
- 18. After the winch assembly is complete, check all capscrews and fittings to make certain they have been tightened correctly.

Refill the winch with the recommended oil listed under "Preventive Maintenance," and install the oil level plug.

Operate the winch slowly in both directions and check for oil leaks and/or unusual sounds from the winch. The winch should operate smoothly in both directions. Refer to "WIRE AND BRAIDED ROPE INSTALLATION" and properly install rope onto the winch drum.

Before returning the winch to full service, a light load should be lifted and held a few feet off the ground to be sure the static brake is functioning properly. The winch should also be able to slowly lower the load in a smooth and controlled manner. If the winch does not perform either of these functions, refer to "TROUBLESHOOTING" for additional information.

# BRAKE VALVE SERVICE

The BRADEN brake valve is a reliable hydraulic valve with internal components manufactured to close tolerances. Because of the close tolerances and mating of components, the valve housing, spool, piston and check poppet are not available as replacement parts.

Before disassembling the brake valve, be sure to conduct all applicable troubleshooting operations and make certain the brake valve is causing the malfunction.

Thoroughly clean the outside surfaces of the valve and work in a clean dust free area, as cleanliness is of utmost importance when servicing hydraulic components.

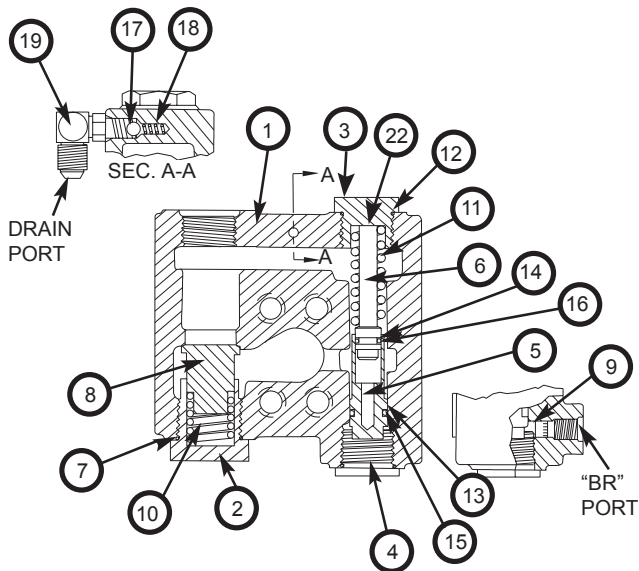

BRAKE VALVE ASSEMBLY		
ITEM	DESCRIPTION	QTY.
1	Valve Housing (NSS)	1
2	Check Valve Retainer (NSS)	1
3	Spring Retainer (NSS)	1
4	Plug (NSS)	1
5	Spool (NSS)	1
6	Damper Piston (NSS)	1
7	O-ring	1
8	Check Valve Poppet (NSS)	1
9	Pilot Orifice	1
10	Check Valve Spring	1
11	Spool Spring	1
12	O-ring	2
13	O-ring	1
14	O-ring	1
15	Back-up Ring	1
16	Back-up Ring	1
17	Check Ball (1/4 in.)	1
18	Check Ball Spring	1
19	Elbow Fitting	1
22	Shim	A.R.

NSS - NOT SERVICED SEPARATELY. REPLACE COMPLETE VALVE ASSEMBLY.

## DISASSEMBLY

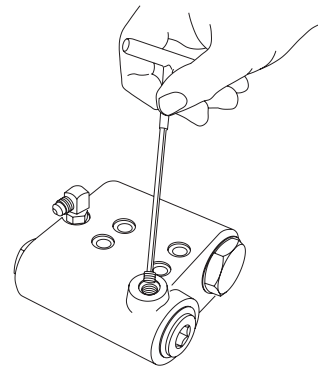

1. Remove the pilot orifice from the brake release (BR) port using a 5/32-inch Allen wrench.

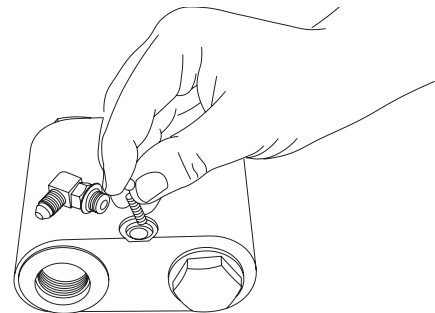

2. Remove the elbow fitting, motor drain check ball and spring.
3. Remove the spool spring retainer and spool spring. Check spring free length. Replace spring if less than 1-15/16 inches (49.2 mm) long.

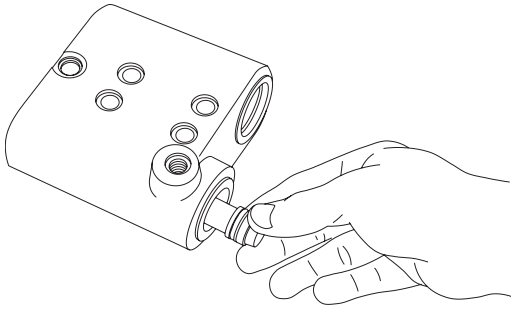

4. Remove spool plug and carefully remove spool assembly.
5. Remove the damper piston from the spool. The piston will come out slowly, because of a partial vacuum formed as it is removed. Use extreme care to avoid damaging the polished surfaces of the piston or spool.

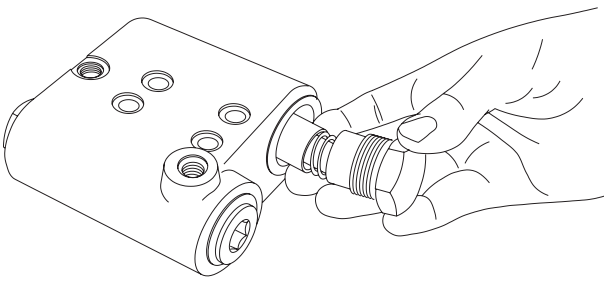

6. Remove the check valve spring retainer, spring and check valve poppet. Check spring free length. Replace spring if less than 1-1/2 inches (38.1 mm) long.

## CLEAN AND INSPECT

1. Discard all O-rings and backup rings. Clean all parts in solvent and blow dry. Inspect polished surfaces of spool and damper piston for damage that may cause binding or leakage. Inspect spool bore in valve housing for damage or scoring. Inspect check valve seat in valve housing and check valve poppet. If the spools, bores or valves are damaged, the entire valve must be replaced as these parts are not serviced separately.

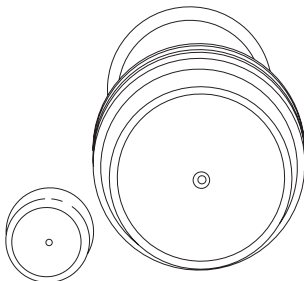

2. Inspect the .020-inch orifice in the end of the spool and the pilot orifice to be certain they are open.

## ASSEMBLY

1. Install new O-rings on the plug and spring retainers.

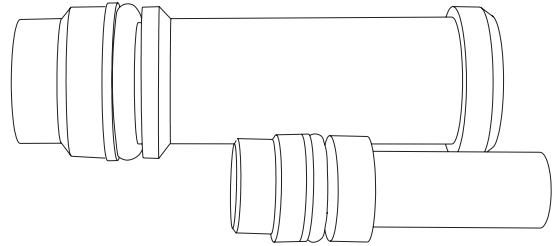

2. Install new O-rings and backup rings on the spool and damper piston as shown. It is important that each backup ring is on the correct side of its O-ring. Take care not to cut the O-rings during assembly. Let the spool and damper piston set for ten minutes before installing them in their respective bores. This will allow the O-rings to return to their original size after being stretched.
3. Lubricate the spool and damper piston O-rings with hydraulic oil. Carefully install the damper piston into the spool.

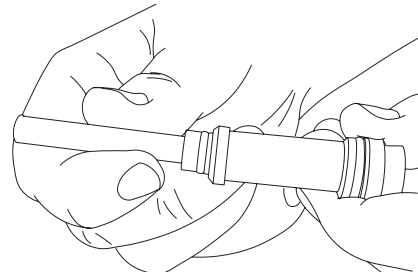

4. Lubricate the spool bore and spool O-rings with hydraulic oil. Carefully install the spool into the valve housing. Always install the spool from the plug end as shown to minimize the possibility of damaging the O-ring. Install the plug, spool spring and spring retainer.
5. Install the check valve poppet, spring and check valve spring retainer.
6. Install the motor drain check ball, spring and elbow fitting.
7. Install the pilot orifice into the valve housing.
8. The brake valve is complete and ready to be installed on the winch motor.

# REVERSING DIRECTION OF DRUM ROTATION (020, 029, 034, 039 motors ONLY)

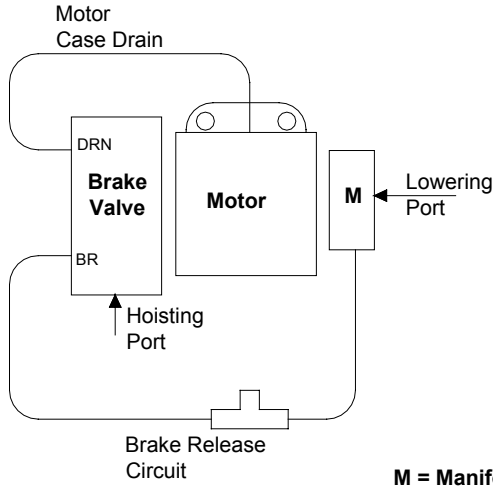

**Figure 3**

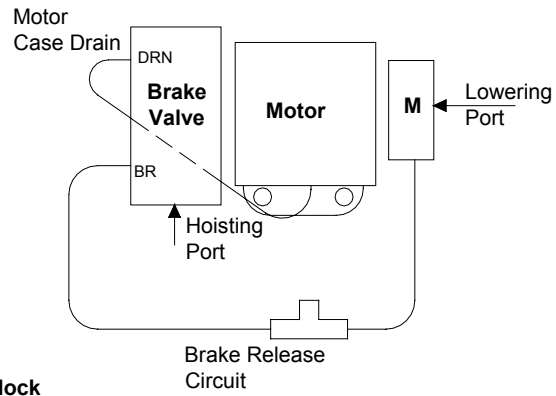
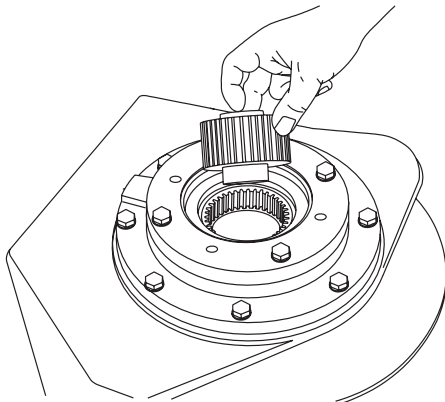

**Figure 4**

To change the direction of rotation, two things must be changed on the winch. First, the motor must be made to rotate in the opposite direction. This is accomplished by exchanging positions of the brake valve and manifold block on the motor. Secondly, the brake clutch assembly must be made effective for the opposite direction of rotation. This is accomplished by reversing the inner race of the brake clutch assembly.

Figures 3 and 4 above show typical BG8 motor installations. Note that the only difference between the two drawings is the motor is rotated 180° (the “belly” of the motor moves to the opposite side). If the motor shaft rotates clockwise in Figure 3 when the hoisting port is pressurized, it will rotate counterclockwise in Figure 4.

1. Remove the four capscrews securing the brake valve to the motor. Remove the four capscrews securing the manifold block to the motor. Disconnect the motor case drain hose at the motor. **NOTE:** Some installations have the brake release hose connected directly to the motor, instead of to the manifold block. In this case, disconnect the brake release hose at the motor port. Stand winch up on drum support with the motor end up and secure in this position.
2. Before removing the motor, it is a good idea to note or mark the position of the motor in relation to the winch, since it will be rotated 180° when reinstalled. Remove the capscrews securing the motor to the winch and carefully remove the motor.
3. Remove the brake clutch assembly from the motor support. Turn the clutch over and re-install it into the center of the brake pack. Be sure the inner race engages the input planet gear shaft.
4. Install a new O-ring on the motor pilot. Rotate the motor 180° from its original position and install it onto the winch. Install and tighten motor capscrews to recommended torque.
5. Install new O-rings in the brake valve and manifold block. Attach the brake valve and manifold block to the motor using the original capscrews and tighten to recommended torque.
6. Connect the motor case drain hose to the motor case drain port.
7. If your winch had the brake release hose connected directly to the motor, the original motor port must be plugged and the hose connected to the motor pressure port near the manifold block (lowering port).
8. Operate the winch slowly in both directions and check for oil leaks and/or unusual sounds from the winch. The winch should operate smoothly in both directions. Refer to “WIRE AND BRAIDED ROPE INSTALLATION” and properly install rope onto the winch drum.



9. Before returning the winch to full service, a light load should be lifted and held a few feet off the ground to be sure the static brake is functioning properly. The winch should also be able to slowly lower the load in a smooth and controlled manner. If the winch does not perform either of these functions, refer to “TROUBLESHOOTING” for additional information.

## RECOMMENDED FASTENER TORQUE

Higher or lower torques for special applications will be specified such as the use of spanner nuts, nuts on shaft ends, jam nuts and where distortion of parts or gaskets is critical.

Lubricated torque values based on use of SAE 30W engine oil applied to threads and face of bolt or nut.

Avoid using thread lubricants as the applied torque may vary by 10-40% depending upon product used.

Bolt Diam. Inches	Thread per inch	Torque LB-FT (N.m)			
		Grade 5		Grade 8	
		Dry	Lubed	Dry	Lubed
1/4	20	8	6	12	9
	28	(11)	(8)	(16)	(12)
5/16	18	17	13	24	18
	24	(23)	(17)	(33)	(24)
3/8	16	31	23	45	35
	24	(42)	(31)	(61)	(47)
7/16	14	50	35	70	50
	20	(68)	(47)	(95)	(68)
1/2	13	75	55	110	80
	20	(102)	(75)	(149)	(108)
9/16	12	110	80	150	110
	18	(149)	(108)	(203)	(149)
5/8	11	150	115	210	160
	18	(203)	(156)	(285)	(217)

Bolt Diam. Inches	Thread per inch	Torque LB-FT (N.m)			
		Grade 5		Grade 8	
		Dry	Lubed	Dry	Lubed
3/4	10	265	200	380	280
	16	(359)	(271)	(515)	(380)
7/8	9	420	325	600	450
	14	(569)	(441)	(813)	(610)
1	8	640	485	910	680
	14	(868)	(658)	(1234)	(922)
1 1/8	7	790	590	1290	970
	12	(1071)	(800)	(1749)	(1315)
1 1/4	7	1120	835	1820	1360
	12	(1518)	(1132)	(2468)	(1817)
1 3/8	6	1460	1095	2385	1790
	12	(1979)	(1485)	(3234)	(2427)
1 1/2	6	1940	1460	3160	2370
	12	(2360)	(1979)	(4284)	(3214)

To convert LB-FT to Kg-m, multiply LB-FT value by 0.1383

8-2008

# METRIC CONVERSION TABLE

## English to Metric

## Metric to English

### LINEAR

inches (in.)	X 25.4	= millimeters (mm)	millimeters (mm)	X 0.03937	= inches (in.)
feet (ft.)	X 0.3048	= meters (m)	meters (m)	X 3.281	= feet (ft.)
miles (mi.)	X 1.6093	= kilometers (km)	kilometers (km)	X 0.6214	= miles (mi.)

### AREA

inches <sup>2</sup> (sq.in.)	X 645.15	= millimeters <sup>2</sup> (mm <sup>2</sup> )	millimeters <sup>2</sup> (mm <sup>2</sup> )	X 0.000155	= inches <sup>2</sup> (sq.in.)
feet <sup>2</sup> (sq.ft.)	X 0.0929	= meters <sup>2</sup> (m <sup>2</sup> )	meters <sup>2</sup> (m <sup>2</sup> )	X 10.764	= feet <sup>2</sup> (sq.ft.)

### VOLUME

inches <sup>3</sup> (cu.in.)	X 0.01639	= liters (l)	liters (l)	X 61.024	= inches <sup>3</sup> (cu.in.)
quarts (qts.)	X 0.94635	= liters (l)	liters (l)	X 1.0567	= quarts (qts.)
gallons (gal.)	X 3.7854	= liters (l)	liters (l)	X 0.2642	= gallon (gal.)
inches <sup>3</sup> (cu.in.)	X 16.39	= centimeters <sup>3</sup> (cc)	centimeters <sup>3</sup> (cc)	X 0.06102	= inches <sup>3</sup> (cu.in.)
feet <sup>3</sup> (cu.ft.)	X 28.317	= liters (l)	liters (l)	X 0.03531	= feet <sup>3</sup> (cu.ft.)
feet <sup>3</sup> (cu.ft.)	X 0.02832	= meters <sup>3</sup> (m <sup>3</sup> )	meters <sup>3</sup> (m <sup>3</sup> )	X 35.315	= feet <sup>3</sup> (cu.ft.)
fluid ounce (fl.oz.)	X 29.57	= milliliters (ml)	milliliters (ml)	X 0.03381	= fluid ounce (fl.oz.)

### MASS

ounces (oz.)	X 28.35	= grams (g)	grams (g)	X 0.03527	= ounces (oz.)
pounds (lbs.)	X 0.4536	= kilograms (kg)	kilograms (kg)	X 2.2046	= pounds (lbs.)
tons (2000 lbs.)	X 907.18	= kilograms (kg)	kilograms (kg)	X 0.001102	= tons (2000 lbs.)
tons (2000 lbs.)	X 0.90718	= metric tons (t)	metric tons (t)	X 1.1023	= tons (2000 lbs.)
tons (long) (2240 lbs.)	X 1013.05	= kilograms (kg)	kilograms (kg)	X 0.000984	= tons (long) (2240 lbs.)

### PRESSURE

inches Hg (60°F)	X 3600	= kilopascals (kPa)	kilopascals (kPa)	X 0.2961	= inches Hg (60°F)
pounds/sq.in. (PSI)	X 6.895	= kilopascals (kPa)	kilopascals (kPa)	X 0.145	= pounds/sq.in. (PSI)
pounds/sq.in. (PSI)	X 0.0703	= kilograms/sq.cm. (kg/cm <sup>2</sup> )	kilograms/sq.cm. (kg/cm <sup>2</sup> )	X 14.22	= pounds/sq.in. (PSI)
pounds/sq.in. (PSI)	X 0.069	= bars	bars	X 14.5	= pounds/sq.in. (PSI)
inches H <sub>2</sub> O (60°F)	X 0.2488	= kilopascals (kPa)	kilopascals (kPa)	X 4.0193	= inches H <sub>2</sub> O (60°F)
bars	X 100	= kilopascals (kPa)	kilopascals (kPa)	X 0.01	= bars

### POWER

horsepower (hp)	X 0.746	= kilowatts (kW)	kilowatts (kW)	X 1.34	= horsepower (hp)
ft.-lbs./min.	X 0.0226	= watts (W)	watts (W)	X 44.25	= ft.-lbs./min.

### TORQUE

pound-inches (in.-lbs.)	X 0.11298	= newton-meters (N-m)	newton-meters (N-m)	X 8.851	= pound-inches (in.-lbs.)
pound-feet (ft.-lbs.)	X 1.3558	= newton-meters (N-m)	newton-meters (N-m)	X 0.7376	= pound-feet (ft.-lbs.)
pound-feet (ft.-lbs.)	X .1383	= kilograms/meter (kg-m)	kilogram/meter (kg-m)	X 7.233	= pound-feet (ft.-lbs.)

### VELOCITY

miles/hour (m/h)	X 0.11298	= kilometers/hour (km/hr)	kilometers/hour (km/hr)	X 0.6214	= miles/hour (m/h)
feet/second (ft./sec.)	X 0.3048	= meter/second (m/s)	meters/second (m/s)	X 3.281	= feet/second (ft./sec.)
feet/minute (ft./min.)	X 0.3048	= meter/minute (m/min)	meters/minute (m/min)	X 3.281	= feet/minute (ft./min.)

### TEMPERATURE

$$^{\circ}\text{Celsius} = 0.556 (^{\circ}\text{F} - 32)$$

$$^{\circ}\text{Fahrenheit} = (1.8^{\circ}\text{C}) + 32$$

### COMMON METRIC PREFIXES

mega	(M)	= 1,000,000 or 10 <sup>6</sup>	deci	(d)	= 0.1 or 10 <sup>-1</sup>
kilo	(k)	= 1,000 or 10 <sup>3</sup>	centi	(c)	= 0.01 or 10 <sup>-2</sup>
hecto	(h)	= 100 or 10 <sup>2</sup>	milli	(m)	= 0.001 or 10 <sup>-3</sup>
deka	(da)	= 10 or 10 <sup>1</sup>	micro	(μ)	= 0.000.001 or 10 <sup>-6</sup>